

To buy, sell, rent or trade-in this product please click on the link below:
<https://www.avionteq.com/Mid-Continent-TT43-Battery-Tester-Charger.aspx>



TRUE BLUE POWER™

A division of Mid-Continent Instrument Co., Inc. — www.truebluepowerusa.com

INSTALLATION MANUAL AND OPERATING INSTRUCTIONS

TT43 Battery Tester/Charger



True Blue Power® is a division of Mid-Continent Instrument Co., Inc.

Manual number 9017682
Rev D, August 22, 2014

FORWARD

The True Blue Power TT43 was created specifically to test and charge Mid-Continent Instrument Company's 4300 Series *Lifesaver*® and the True Blue Power TS420 Series battery packs. This manual provides information intended for use by persons who are qualified to repair and service Mid-Continent Instrument Company's 4300-4xx Series Electric Attitude Gyro; the *LifeSaver*®. If further information is required, please contact:

We welcome your comments concerning this manual. Although every effort has been made to keep it free of errors, some may occur. When reporting a specific problem, please describe it briefly and include the manual part number, the paragraph/figure/table number, and the page number. Send your comments to:

All products produced by Mid-Continent Instruments Co., Inc., including those identified as Mid-Continent Instruments and Avionics or True Blue Power, are designed and manufactured in Wichita, Kansas, USA.

©Copyright 2014
Mid-Continent Instrument Co., Inc.

REVISION HISTORY

<u>ECO</u>	<u>Rev.</u>	<u>Date</u>	<u>Detail</u>
	A	06/28/12	Initial release.
5812	B	08/14/12	Clarification of wording in annual test procedure section. Clarification of wording in section five paragraph one.
6112	C	4/21/2014	Updated capacity test times for passing indication.
6235	D	8/22/2014	Updated Section 3 Test Procedure for clarification.

Table of Contents

SECTION 1	GENERAL DESCRIPTION	5
1.1	INTRODUCTION	5
1.2	FEATURES	5
SECTION 2	OPERATION	6
2.1	POWER	6
2.2	CHARGING BATTERY	6
2.3	TESTING BATTERY CAPACITY (DISCHARGE TIME):	7
SECTION 3	MAINTENANCE	8
3.1	TEST PROCEDURE FOR TT43 BATTERY TESTER/CHARGER	8
3.2	RECYCLE INFORMATION	11

Section 1 GENERAL DESCRIPTION

1.1 INTRODUCTION

The True Blue Power battery tester/charger is used for charging and testing the Mid-Continent Instrument Company battery P/N's 9015607 and 9016925, used primarily with the 4300-4xx Electric Attitude Indicator and TS420/TS420-1 Battery Backup Systems.

1.2 FEATURES

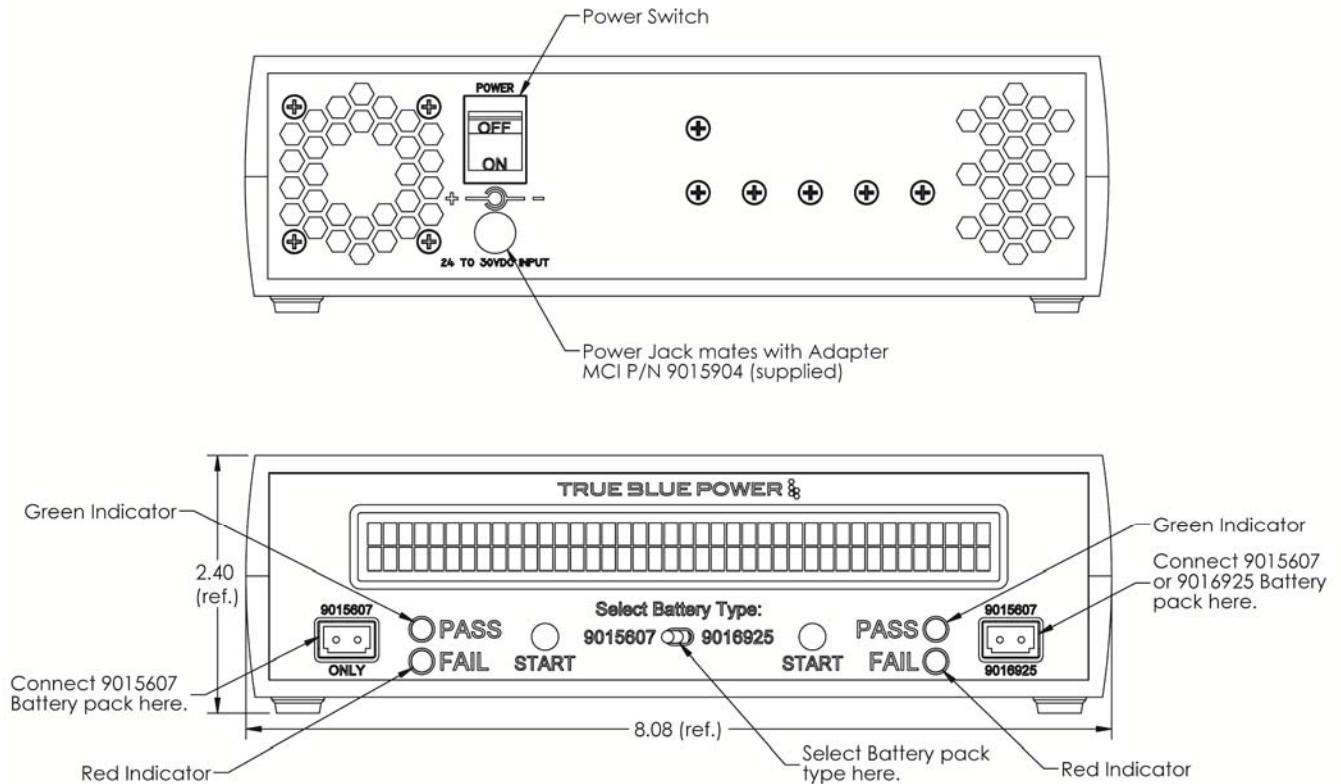

Figure 1
Battery Charger Control Panel

The following indicators are provided:

Digital Dot Matrix LCD Screen: Displays current process (i.e. charging/testing)

Pass: When illuminated indicates test of battery has tested good and battery does not need to be replaced.

Fail: When illuminated indicates the battery has failed the test and it is recommended that the battery be replaced.

Section 2 OPERATION

2.1 Power

Plug the AC Adapter* (MCI P/N 9015904) into a standard wall outlet, and on the back of the test box. When the switch on the back of the unit is in the "ON" position, the LCD screen will illuminate and display start up screen followed by the battery charging screen. The battery tester/charger is now ready to use.

* AC Adapter – Input: 90-264VAC, 50/60Hz, 30W. Output: 24VDC, 1.25A

2.2 Charging Battery

IMPORTANT BATTERY INFORMATION

- A) Do not charge a battery that shows signs of leakage or corrosion.
- B) Do not charge a battery at extreme temperatures. It is recommended to charge the Battery in a moderate temperature environment, avoiding extremes of either hot or cold.
- C) The Battery can be left on float charge indefinitely. Float charging will maintain the best possible conditions to maintain the life of the battery.
- D) The battery may be safely charged in any physical orientation.
- E) If battery has charged for 9 hours or more but the LCD still indicates "Charging", unplug the battery and check battery voltage to see if it is $20.5VDC \pm 0.5V$. Plug battery pack into the charger and wait for one minute, if the system indicates "FLOAT" and the current is 25mADC or less, the battery is already fully charged. Proceed with Section 6 Testing Battery Capacity if this test has not been performed prior to the charge. (Use this method to verify a full charge battery ONLY IF "FLOAT" is not indicated and current is not less than 25mADC after charging for 9 or more hours.)

Note: Only charge or test Mid-Continent Instrument Company battery P/N's 9015607 and 9016925 with the TT43 Battery Tester/Charger. Charging or testing other types of batteries may damage the charger.

Plug the battery (P/N 9015607 or 9016925) into corresponding connector either labeled "9015607 ONLY" or you may plug the battery into the connector labeled with "9015607" or "9016925" with the charger powered on. If you have chosen to plug the battery into the connector labeled "9015607" or "9016925" then you will need to ensure that the center toggle switch is moved to the appropriate position selecting which battery, either 9015607 or 9016925, to be charged or tested. If the battery is not fully charged, the battery will immediately start charging with the screen displaying "CHARGING". Full charge may take up to 6 hours depending on battery type. The system will charge either two 9015607 batteries simultaneously or one 9015607 and one 9016925 simultaneously.

When full charge is reached, the screen will indicate "FLOAT". When this is indicated the charger is now in float mode and will maintain the Battery in full charge condition.

2.3 **Testing Battery Capacity (Discharge Time):**

The process to test the battery life is a measure of the time to discharge a fully charged battery into a load similar to that required to power a 4300-4XX gyro or the TS420/TS420-1 in emergency modes. Follow the steps below to run the test:

- A) Connect the battery taking care to select the correct battery if using the port labeled "9015607 or 9016925", and then allow at least 1 minute for stabilization of the battery condition before pushing the "START" button.
- B) Push the white "START" button and hold it in for at least 2 seconds then release. The battery charger will then check to see if the battery is fully charged. If the battery is fully charged it will begin the test. If the battery is not fully charged it will display "TESTING" along with "CHARGING" to indicate a charge cycle has to finish before the test can be started. Once the battery is fully charged the system will begin the test by applying a constant discharge load. At this time below the "TESTING" indication on the screen a timer will start counting up. When discharge is completed, the indication will become "TEST DONE". If discharge time is less than 60 minutes for 9015607 or less than 3 hours and 54 minutes for 9016925, the system will illuminate the FAIL indicator and it is recommended that the battery be replaced. If discharge time is 60 minutes or more for 9015607, the PASS indicator will light and the system will continue discharging the battery. If discharge time is 3 hours and 54 minutes or more for 9016925, the PASS indicator will light and the system will continue discharging the battery.
- C) The PASS or FAIL LEDs provide an indication based on a generic requirement of meeting 80% of the capacity of a new battery. However, for any particular installation, the power and duration needed may represent a different capacity requirement. The actual requirement in the installation must be considered before returning the battery to service. To evaluate the battery's capacity, consider the discharge time as provided by the battery charger. This measures how long the battery under test can apply power to a 490 mA load. This value serves as a point of reference for determining capacity in the specific installation.
- D) After the battery discharge cycle is complete, the battery tester/charger will automatically switch to fast charging mode and alternate between "CHARGING" and "TEST DONE" screens.
- E) Allow the battery to fully charge before use (See Section 5 Charging Battery).

Section 3 MAINTENANCE

3.1 TEST PROCEDURE FOR TT43 BATTERY TESTER/CHARGER

Annual Verification of TT43 Tester/Charger performance is recommended.

Test Equipment:

Unit Under Test (UUT) (6430043-1)
AC Adapter (24VDC) (9015904)
Regulated DC Power Supply (0-30V, 1A)
DC Ammeter
DC Voltmeter
23 ohm power resistor rated greater than 20 watts

Test Procedure:

Note: "Long press" means press and hold the START button for 4 seconds then release.

1. Plug 24V AC adapter (9015904), into rear connector of UUT (6430043-1) and into wall outlet. Power on UUT. The screen should display True Blue Power screen, then change to the main battery screen.
2. UUT should display 20.5V \pm 0.2V for both ports.
3. Long press START on the 9015607 ONLY port. The red FAIL LED should turn on, and the unit will alternate between a TEST DONE screen and the main battery screen. Long press START again to clear. Repeat this step on 9015607/9016925 port. Power off UUT.
4. Connect test setup per Figure 1:

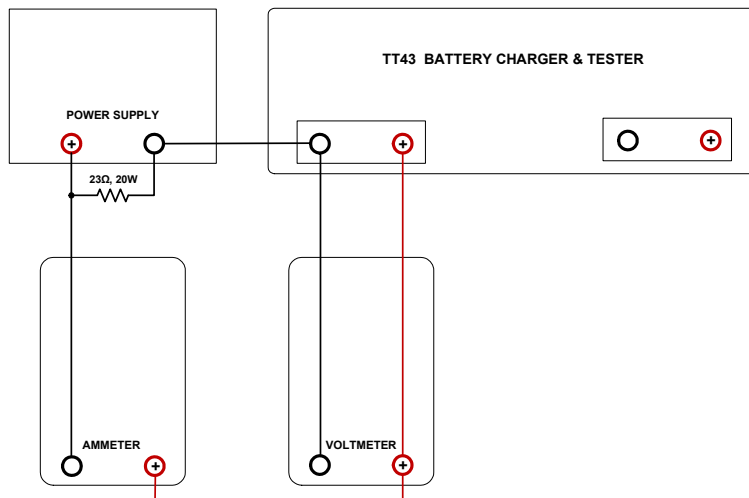

Figure 1: Test Connections

5. Turn on power supply and adjust voltage to 22.0V.
6. Power on UUT. Voltmeter should read 22.0V \pm 0.2V and ammeter should read -3mA \pm 1mA. The UUT should display FLOAT.

7. Reduce the voltage of the power supply until Voltmeter reads 20.0V, then long press START on the 9015607 ONLY port. The UUT should read CHARGING. The ammeter should read 220mA or greater. The current displayed on screen should match the ammeter within $\pm 10\text{mA}$. Long press START on the 9015607 ONLY port. The voltage displayed on screen should match the voltmeter within $\pm 0.4\text{V}$.
8. Increase the voltage of the power supply to 22.0V. The UUT should display FLOAT. Voltmeter should read $22.0\text{V} \pm 0.4\text{V}$, and ammeter should read $-3\text{mA} \pm 1\text{mA}$.
9. Move the test setup to the right side port labeled 9015607/9016925 with Battery Type switch selecting the 9015607 battery. Adjust power supply to 22.0V.
10. Reduce the voltage of the power supply until Voltmeter reads 20.0V, then long press START on the 9015607/9016925 port. The UUT should display CHARGING. The ammeter should read 220mA or greater. The current on screen should match the ammeter within $\pm 10\text{mA}$. Long press START on the 9015607/9016925 port. The voltage displayed on UUT should match the voltmeter within $\pm 0.4\text{V}$.
11. Increase the voltage of the power supply to 22.0V. The UUT should display FLOAT. Voltmeter should read $22.0\text{V} \pm 0.4\text{V}$, and ammeter should read $-3\text{mA} \pm 1\text{mA}$.
12. Set Battery Type switch to the 9016925 position. Reduce the voltage of the power supply until Voltmeter reads 20.0V. Long press START on the 9015607/9016925 port. The UUT should display CHARGING. The ammeter should read 450mA or greater.
13. Long press START on the 9015607/9016925 port. Increase the power supply to 22.0V. The UUT should read FLOAT. UUT voltage should display $22.0\text{V} \pm 0.4\text{V}$ and ammeter should read $-3\text{mA} \pm 1\text{mA}$.
14. Turn off power supply and the UUT.
15. Connect test setup per Figure 2:

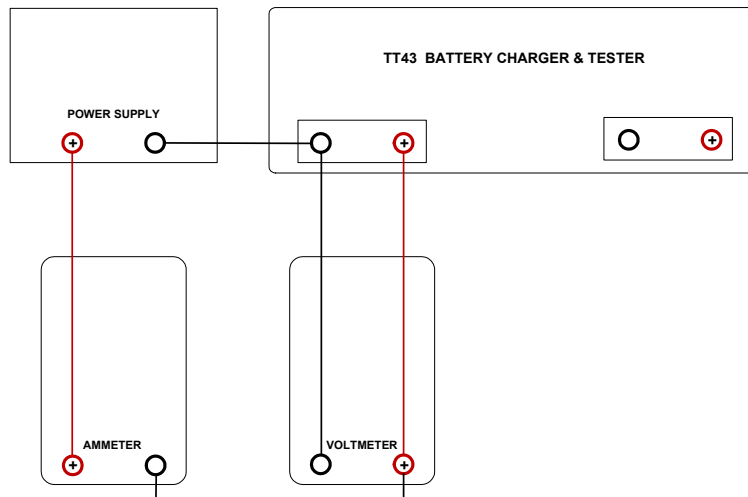

Figure 2: Test Connections

16. Turn on the power supply and the UUT and adjust the voltage to 22.0V.

17. Long press START on the 9015607 ONLY port. The screen should change to TESTING, and the timer should start counting up.
18. The ammeter should read $246\text{mA} \pm 10\text{mA}$. After approximately 5 to 10 seconds reduce the voltage of the power supply to less than 15.5V. The UUT should display TEST DONE and turn on the red FAIL LED.
19. Long press START on the 9015607 ONLY port to clear the UUT back to the main battery screen. The red FAIL LED should go out.
20. Move the test setup to the right side port labeled 9015607/9016925 with Battery Type switch selecting the 9015607 battery. Adjust power supply to 22.0V.
21. Long press START on the 9015607/ 9016925 port. The screen should change to TESTING, and the timer should start counting up.
22. The ammeter should read $246\text{mA} \pm 10\text{mA}$. After approximately 5 to 10 seconds reduce the voltage of the power supply to less than 15.5V. The UUT should display TEST DONE and illuminate the red FAIL LED.
23. Long press START on the 9015607/9016925 port to clear the UUT back to the main battery screen. The red FAIL LED should go out.
24. Set the battery selection switch to 9016925 and adjust power supply to 22.0V.
25. Long press START on the 9015607/9016925 port. The UUT should display TESTING and the timer should count up. The fan should begin to run immediately.
26. The ammeter should read $498\text{mA} \pm 10\text{mA}$. After approximately 5 to 10 seconds reduce the voltage of the power supply to less than 15.5V. The fan should stop running and the UUT should display TEST DONE with the red "FAIL" LED on.
27. Long press START on the 9015607/9016925 port to clear the UUT back to the main battery screen. The red FAIL LED should go out.
28. Test is complete. Power off and unplug UUT from Test Set.

3.2 **RECYCLE INFORMATION**

- A) Store spent batteries under cover and on an impervious surface.
- B) Keep spent batteries from freezing to avoid cracking their cases.
- C) DO NOT dispose of spent batteries in the trash or any landfill. The battery contains lead and MUST be routed to a recycling center.
- D) Choose a reputable battery recycler. Call 1-800-8BATTERY for a location near you or visit www.rbrc.org.