

To buy, sell, rent or trade-in this product please click on the link below:
<http://www.avionteq.com/Barfield-1811-PN-101-00168-Pitot-Static-Test-Set.aspx>



1811G/H PITOT-STATIC TEST SET

USER INSTRUCTION MANUAL

M/N: 1811G/H, P/Ns: 101-00165
101-00168
101-00169

Doc. P/N: 56-101-00165/168/169
Revision A
September 9, 2009

BARFIELD, INC.



Corporate Headquarters

4101 Northwest 29th Street

Miami, Florida 33142

www.barfieldinc.com

Email: g-sales@barfieldinc.com

THIS PAGE INTENTIONALLY LEFT BLANK

THIS PAGE INTENTIONALLY LEFT BLANK



1811G/H INSTRUCTION MANUAL

CONTACT INFORMATION

Users are requested to notify the manufacturer of any discrepancy, omission, or error found in this manual. Inquiries should include specific questions and reference the publication title, number, chapter, page, figure, paragraph, and effective date.

Please send comments to:

**TECHNICAL CUSTOMER SUPPORT - GSTE
BARFIELD, INC.
P.O. BOX 025367
MIAMI, FL 33102-5367
USA**

Telephone	(305) 894-5400 (800) 321-1039
Fax	(305) 894-5401
Email	gsesales@barfieldinc.com

THIS PAGE INTENTIONALLY LEFT BLANK



1811G/H INSTRUCTION MANUAL

ATTENTION

Although every effort has been made to provide the end user of this equipment with the most current and accurate information, it may be necessary to revise this manual in the future. Please be sure to complete and return the enclosed **OWNER WARRANTY REGISTRATION CARD** to Barfield in order to validate the warranty and to ensure that you will receive updated information when published. You **MUST** have your name and address on file at Barfield as a registered user of this equipment, to be able to obtain the service covered by the warranty.

Visit the company website, <http://barfieldinc.com/>, for publication updates.

Please send the Registration Card to:

Barfield, Inc.
P.O. Box 025367
Miami, FL 33102-5367
USA

THIS PAGE INTENTIONALLY LEFT BLANK



1811G/H INSTRUCTION MANUAL

REVISION RECORD

REV.	ECO #	REV. DATE	DESCRIPTION OF CHANGE
A	260-00729	September 9, 2009	Initial Release, prepared from Technical Manual 57-101-00165/00168/00169 (TM1811G/H-8111, revised on March 12, 1991), to update company logo, contact information and format.

THIS PAGE INTENTIONALLY LEFT BLANK



1811G/H INSTRUCTION MANUAL

MAINTENANCE AND REPAIR INFORMATION

The manufacturer of this equipment does not recommend the user to attempt any maintenance or repair. In case of malfunction, contact the manufacturer, to obtain the list of approved repair facilities worldwide, ensuring that this equipment will be serviced using proper procedures and certified instruments. A Return Maintenance Authorization (RMA) number will be assigned during this call, to keep track of the shipment and the service.

BARFIELD PRODUCT SUPPORT DIVISION

Telephone (305) 894-5400
(800) 321-1039

Fax (305) 894-5401

Shipping Address:

Barfield, Inc.
4101 NW 29th Street
Miami, Florida 33142
USA

Mailing Address:

Barfield, Inc.
P.O. Box 025367
Miami, FL 33102-5367
USA

THIS PAGE INTENTIONALLY LEFT BLANK



1811G/H INSTRUCTION MANUAL

TABLE OF CONTENTS

Contact Information
Attention Page
Revision Record Page
Maintenance and Repair Information
Table of Contents

	Page
INTRODUCTION	
1. PUBLICATION BREAKDOWN	1
2. INFORMATION PROVIDED WITH THE UNIT	1
3. RECERTIFICATION.....	2
CHAPTER 1: DESCRIPTION	
1. PURPOSE OF MANUAL.....	3
2. GENERAL DESCRIPTION	4
3. SPECIFICATIONS	5
4. PHYSICAL DESCRIPTION.....	7
CHAPTER 2: OPERATION	
1. GENERAL	11
2. PRESSURE/VACUUM SOURCE OPERATION	14
3. PREPARATION FOR TEST	16
4. TESTER LEAK CHECKS	17
5. STATIC SYSTEM LEAKS	19
6. PITOT SYSTEM TESTS.....	21
7. COMBINED PITOT/STATIC SYSTEM TESTS.....	23
8. MACHMETER TEST	25
9. ENGINE PRESSURE RATIO (EPR) TEST	26
10. MANIFOLD PRESSURE GAUGE TEST	27
11. PRESSURE TESTS	29
12. VACUUM TESTS	30
13. SHUTDOWN PROCEDURES	32
CHAPTER 3: SHIPPING	
1. RECEIVING.....	33
2. SHIPPING	33



1811G/H INSTRUCTION MANUAL

TABLE OF CONTENTS (continuation)

	Page
CHAPTER 4: STORAGE	
1. PROCEDURE.....	35
CHAPTER 5: SERVICING	
1. PERIODIC INSPECTION	37
2. INSTRUMENT RECERTIFICATION.....	38
APPENDIX: ENGINEERING SPECIFICATIONS	39
SECTION 1. ALTIMETER.....	41
SECTION 2. AIRSPEED INDICATOR.....	49
SECTION 3. VERTICAL SPEED INDICATOR	57



T A T G R O U P

1811G/H INSTRUCTION MANUAL

INTRODUCTION

1. PUBLICATION BREAKDOWN

This instruction manual establishes the operation standards for the 1811G / H Pitot-Static Test Set.

Its purpose is to provide sufficient information for the personnel unfamiliar with this unit to understand this equipment, identify its parts, and operate it in accordance with proper procedures, operating techniques, precautions and limitations.

2. INFORMATION PROVIDED WITH THE UNIT

Besides this User Instruction Manual, the 1811HA / GA Test Set is provided with the four items described below.

- A. An identification label, located on the front bulkhead of the Test Set, provides the following information:

Manufacturer Name	
Designation of Equipment	
Equipment Part Number	
Equipment Model Number	Equipment Serial Number
Equipment Modification (if applicable)	Equipment Options (if applicable)

- B. The Owner's Warranty Registration card, (Figure 1), which is to be completed by the owner and returned to the Barfield within **ten (10) days** of purchase to insure validation of the warranty.

OWNER WARRANTY REGISTRATION

RETURNING THIS CARD COMPLETED ENABLES US TO KEEP YOU
AUTOMATICALLY INFORMED OF TECHNICAL UPDATES and VALIDATES YOUR WARRANTY.

NAME _____ TITLE _____
DEPARTMENT _____
COMPANY _____
ADDRESS _____
CITY _____ STATE _____ ZIP _____
P/N _____ S/N _____ MODEL # _____
PURCHASED FROM _____ DATE _____
AIRLINE REPAIR STATION OEM
OTHER _____

INFORMATION GIVEN ON THIS BARFIELD, INC. WARRANTY CARD IS AND WILL REMAIN
STRICTLY CONFIDENTIAL AND WILL NOT BE SHARED.

OW-28 REV / 04.00

Figure 1 OWNER WARRANTY REGISTRATION CARD

1811G/H INSTRUCTION MANUAL

- C. The Limited Warranty Statement Card, (Figure 2), which lists the manufacturer's obligation to the original purchaser.

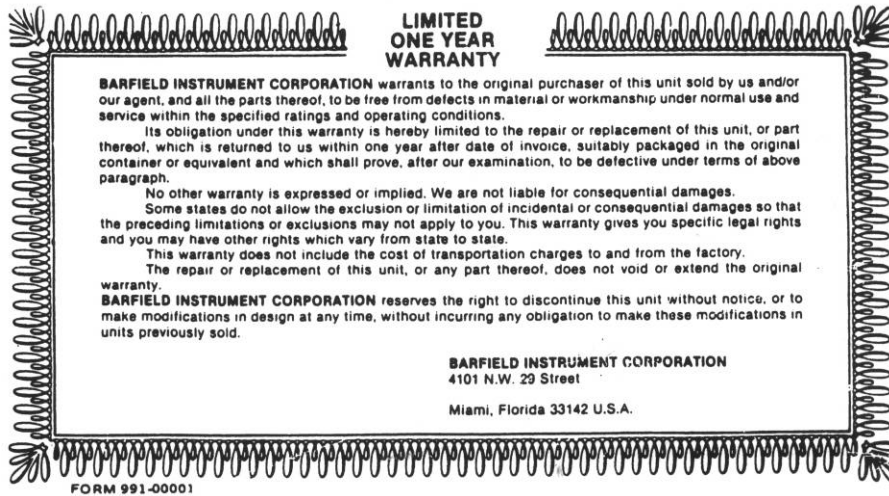

Figure 2 LIMITED WARRANTY STATEMENT CARD

- D. Each new or re-certified unit is delivered with a Certificate that shows the date when the unit was tested by the manufacturer, its serial number, and when the next certification is due. This certificate confirms that the unit performed according to its design specifications.

3. RECERTIFICATION

The Test Sets P/Ns 101-00165, 101-00168, and 101-00169 have a 6-month recertification period when analog instruments are installed.

It is strongly recommended that the manufacturer, Barfield Inc., service the Test Set. This will ensure that all applicable engineering change orders are incorporated during the required maintenance or recertification procedure.

Note: It is important that the customer ensures the Test Set is in compliance with the Recertification requirement.

DESCRIPTION

1. PURPOSE OF MANUAL

This publication contains the description, identification data, operating procedures, servicing, maintenance and recertification information for the:

PITOT-STATIC TEST SET, P/N 1811G/H, hereinafter referred to as the Test Set. Reference Figure 1.

Manufactured by:

Barfield Instrument Corporation; Miami Florida 33142 U.S.A.

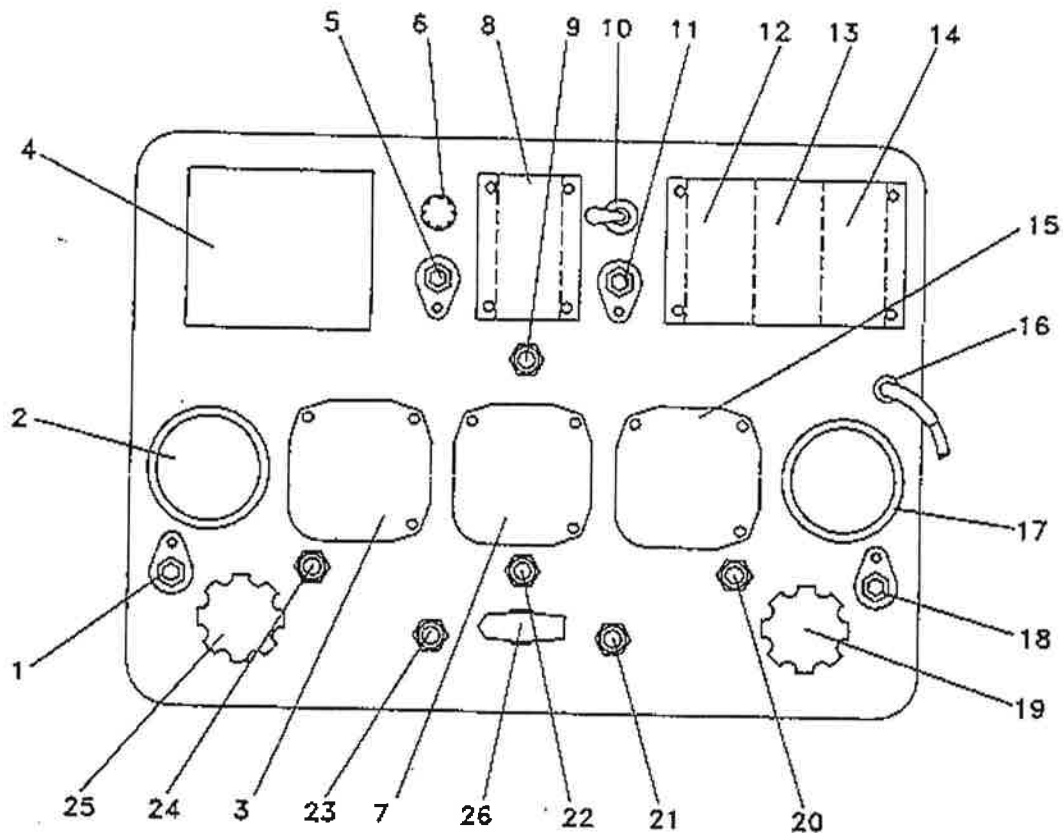

PITOT-STATIC TEST SET P/N 1811G/H
Figure 1

57-101-00165/168/169

1-1
Page 1
March 12/91

FOR REFERENCE ONLY

2. GENERAL DESCRIPTION

The Test Sets is intended for testing aircraft Pitot / Static Systems for leaks; and also for checking the operation and calibration of airspeed, altimeter, rate of climb, engine pressure ratio, manifold pressure indicators, and other vacuum or low pressure units.

BARFIELD INSTRUMENT CORPORATION Pitot-Static Test Set P/N 1811G/H meets the requirements for compliance with FAR 91.171, but it is important that the customer be sure that the use of the test set will be in compliance with other aspects of the regulations. A test procedure guide, P/N 60-101-00150, Altimeter and Static Test Procedure, is available for use in compliance with FAR 91.171.

This Test Set also fully meets the requirements for FAA Advisory Circular 43-203B for performing Altimeter and Static System Tests and Inspections.

The Test Set is equipped with reference master instruments with appropriate calibration cards. An electric pump (H MODEL) supplies the pressure and vacuum to the reservoir tanks of the tester via a panel mounted selector valve. Hand pumps are also provided for use when electrical power is not accessible. Six metering valves control all pneumatic functions. Ports are provided for external pressure/vacuum sources, and for connection to the aircraft Pitot and Static systems.

3. SPECIFICATIONS

A. Physical Data

- (1) Height - 11.3 in. (28.7 cm).
- (2) Width - 20.0 in. (50.8 cm).
- (3) Depth - 16.0 in. (40.6 cm).
- (4) Weight - 1811G Approximately 27 lbs. (12.2 kg).
 - 1811H Approximately 36 lbs. (16.3 Kg).

B. Specifications

- (1) Instruments
 - (a) Airspeed: See Table 1 on page 6.
 - (b) Vertical Speed Indicator: 0-6,000 ft/min.
 - (c) Altimeter: See Table 1 on page 6.
- (2) Pumps
 - (a) Electric (H Model only)
 - pressure: 15 psi (limited internally).
 - vacuum: 25 in. Hg.
 - (b) Hand pump pressure: 20 psi.
 - (c) Hand pump vacuum: 25 in. Hg.
- (3) Power (H Model)
 - (a) 115 VAC 60 Hz.
 - (b) 115 VAC 400 Hz.

There are two (2) basic model numbers: 1811G is for manual operation or in conjunction with an external pressure or vacuum source. 1811H has all the features of the 1811G with the addition of an internal electrical pump to supply vacuum or pressure. Both basic models are housed in a durable fiberglass case. The three digit code following the basic number identifies the various master indicator combinations which are available as per Table 2.

1811H	<input type="text"/>	<input type="text"/>	<input type="text"/>	with electric pump (Specify 115V 60 Hz or 220V 50 Hz)
OR		OR		
1811G	<input type="text"/>	<input type="text"/>	<input type="text"/>	without electric pump

	10	NONE	
1	AIRSPED INDICATOR 650 KNOT RANGE (50 - 650 KNOTS)	1	ALTIMETER, SENSITIVE, 3 ptr., 50,000 FEET, In Hg BARO SCALE
2		2	ALTIMETER, PRECISION DUAL DIAPHRAGM, 3 pts., 80K RANGE CAL TO 55K, In Hg BARO SCALE
3		3	
4	AIRSPED INDICATOR 420 KNOT RANGE (60 - 420 KNOTS)	4	ALTIMETER, SENSITIVE, 3 ptr., 35,000 FEET, In Hg BARO SCALE
5		5	ALTIMETER, SENSITIVE, 3 ptr., 35,000 FEET, In Hg/mib BARO SCALE
6	AIRSPED INDICATOR 250 KNOT RANGE (20 - 250 KNOTS)	6	ALTIMETER, SENSITIVE, 3 ptr., 50,000 FEET, mib BARO SCALE
7		7	ALTIMETER, SENSITIVE, 3 ptr., 35,000 FEET, mib BARO SCALE
8		8	
9	SPECIAL	9	SPECIAL

PART NUMBER VARIATIONS
Table 1

57-101-00165/168/169

FOR REFERENCE ONLY

4. PHYSICAL DESCRIPTION

A. Carrying Case

- (1) The case is of fiberglass construction with upper and lower sections.
- (2) The lower section supports the panel assembly and houses the pump (H MODEL).
- (3) The upper section has sliding pin hinges for easy removal and is fitted with a storage shelf for the hose kit and manual.

B. Panel

The item callouts reference the item numbering in Figure 1. The terms Pitot (pressure) and Static (vacuum) will appear throughout the text.

ITEM	PANEL DESIGNATION	DESCRIPTION	FUNCTION
1	EXTERNAL PRESSURE	FITTING FEMALE BULKHD	PORT FOR EXTERNAL PRESSURE SOURCE
2	PRESSURE TANK	PRESSURE GAUGE (0 - 30 PSI)	MONITOR AVAILABLE PRESSURE IN THE PRESSURE RESERVOIR TANK
3	NONE	AIRSPEED INDICATOR	MONITOR PRESSURE DIFFERENTIAL BETWEEN PRESS AND VAC PORTS
4	NONE	DECAL	PROVIDE INSTRUCTIONS FOR PRE-TESTING TEST SET
5	PRESSURE PORT	FITTING FEMALE BULKHD	PORT FOR CONNECTING AIRCRAFT PITOT SYSTEM
6	3 AMP SLO-BLO (H MODEL)	FUSE HOLDER	HOUSES TEST SET FUSE
7	NONE	VERTICAL SPEED INDICATOR	MONITOR RATE OF CHANGE OF VACUUM AT VAC PORT

PANEL CALLOUTS
Table 2

ITEM	PANEL DESIGNATION	DESCRIPTION	FUNCTION
8	VERTICAL SPEED ERROR	CALIBRATION CARD	PROVIDES ERROR CORRECTION FOR THE VSI
9	VERTICAL SPEED	METERING VALVE	PROVIDES ISOLATION AND/OR CONTROL CONNECTION OF THE VSI
10	INTERNAL PUMP (H MODEL)	TOGGLE SWITCH	USED TO TURN INTERNAL PUMP ON OR OFF
11	VACUUM PORT	FITTING FEMALE BULKHD	PORT FOR CONNECTING AIRCRAFT STATIC SYSTEM
12	AIRSPED IND. ERROR	CALIBRATION CARD	PROVIDES ERROR CORRECTION FOR THE AIRSPEED INDICATOR
13	HYSTERESIS	CALIBRATION CARD	PROVIDES ALTIMETER HYSTERESIS DATA
14	ALTIMETER ERROR	CALIBRATION CARD	PROVIDES ERROR CORRECTION FOR THE ALTIMETER
15	NONE	ALTIMETER	MONITORS PRESSURE ALTITUDE AT THE VAC PORT
16	POWER CORD (H MODEL)	ELECTRICAL CONNECTOR	USED TO CONNECT 115 VAC 60 HZ OR 230 VAC 50 HZ TO TESTER
17	VACUUM TANK	VACUUM GAUGE (0-30 IN. HG)	MONITORS AVAILABLE VACUUM IN THE VACUUM RESERVOIR TANK
18	EXTERNAL VACUUM	FITTING FEMALE BULKHD	PORT FOR EXTERNAL VACUUM SOURCE
19	VACUUM PUMP	HAND OPERATED PISTON PUMP	PROVIDES VACUUM SOURCE OF APPROXIMATELY 25 IN. HG

PANEL CALLOUTS
Table 2 (Cont.)

ITEM	PANEL DESIGNATION	DESCRIPTION	FUNCTION
20	VACUUM CONTROL	METERING VALVE	USED TO CONTROL THE VACUUM SOURCE
21	VACUUM VENT	METERING VALVE	USED TO RELEASE VACUUM TO AMBIENT ATMOSPHERE
22	CROSSBLEED CONTROL	METERING VALVE	USED TO CONTROL THE PRESSURE DIFFERENCE BETWEEN THE PRESS PORT AND VAC PORT
23	PRESSURE VENT	METERING VALVE	USED TO RELEASE PRESSURE TO AMBIENT ATMOSPHERE
24	PRESSURE CONTROL	METERING VALVE	USED TO CONTROL THE PRESSURE SOURCE
25	PRESSURE PUMP	HAND OPERATED PISTON PUMP	PROVIDES PRESSURE SOURCE OF APPROXIMATELY 20 PSI
26	INTERNAL PUMP SELECTOR (H MODEL)	TWO POSITION ROTARY VALVE	FOR SELECTING WHICH RESERVOIR TANK TO SUPPLY OR REPLENISH

PANEL CALLOUTS
 Table 2 (Cont.)

C. Hose Assembly

- (1) The Hose Assembly P/N 115-00056 is used for connecting the Test Set to the Pitot /Static systems.

THIS PAGE INTENTIONALLY LEFT BLANK

OPERATION

I. **GENERAL**

A. Pneumatic Diagram

Figure 1 and 2 presents the pneumatic diagram of the lines and fittings in the Test Set.

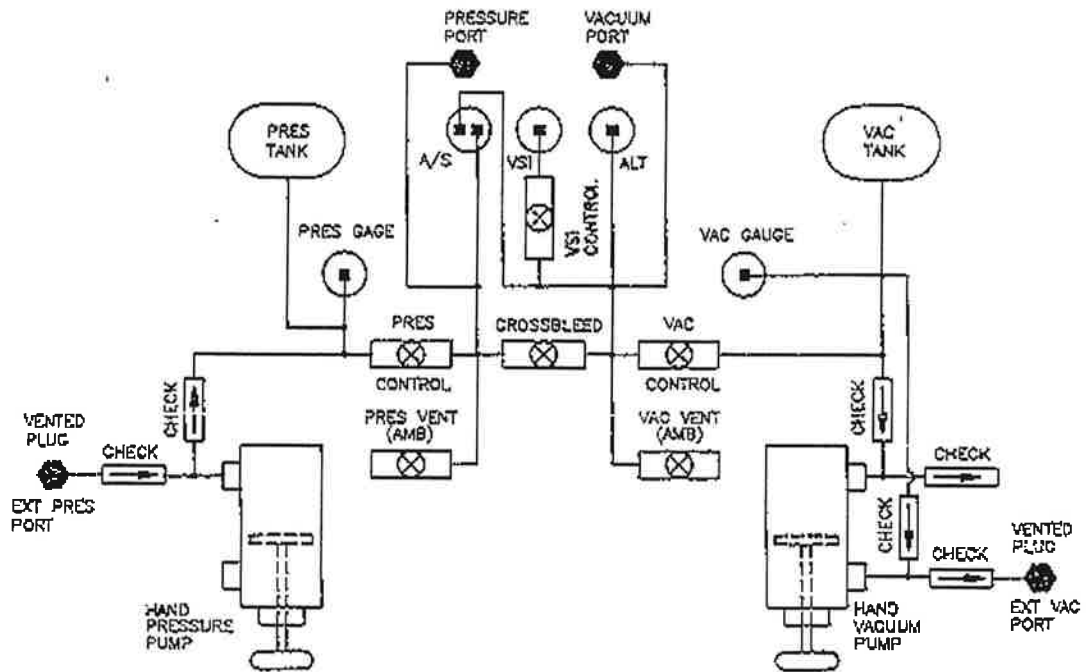

PNEUMATIC DIAGRAM (1811G)
 Figure 1

57-101-00165/168/169

FOR REFERENCE ONLY

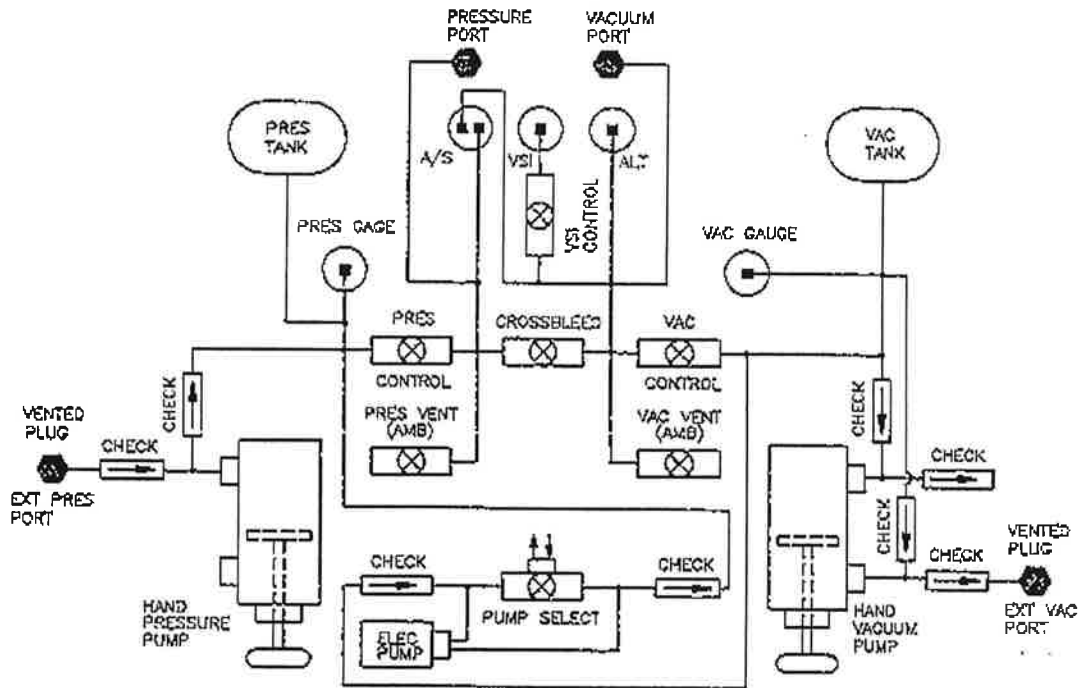

PNEUMATIC DIAGRAM (1811H)
Figure 2

B. Theory Of Operation

With the CROSSBLEED CONTROL and PRESSURE VENT valves closed, the PRESSURE CONTROL valve will provide pressure from the PRESSURE TANK into the system and cause an indication in both the Test Set master airspeed and the instrument or system being tested through the PRESS PORT connection. With the CROSSBLEED CONTROL and VACUUM VENT valves closed, the VACUUM CONTROL valve will provide vacuum from the VACUUM TANK into the system and cause an indication in the Test Set master altimeter and the instrument or system being tested through the VAC PORT. The Test Set master VSI will also react provided the VERTICAL SPEED valve is open.

The PRESSURE VENT and VACUUM VENT valves are used to equalize their respective systems with ambient pressure.

The CROSSBLEED CONTROL valve controls the pressure difference between the pressure and vacuum lines of the Test Set.

By operating the appropriate valves, controlled pressure/vacuum can be established in the Pitot and or Static lines. These pressures appear as readings on the master indicators of the Test Set.

By using the values listed on the calibration cards, the operator can establish known correct pressure conditions with which to compare the reading of the unit under test.

Use of EXTERNAL PRESSURE and EXTERNAL VACUUM ports the INTERNAL PUMP, or the hand operated PRESSURE PUMP and VACUUM PUMP does not affect the operation of the Test Set, since its controls are independent of the sources. The Test Set is designed in such a manner as to allow the use of any of the three sources in place of or in conjunction with each other.

C. Precautions

- (1) The user should become familiar with the Test Set as described in the previous sections, and follow exactly the instructions in the following sections of this manual. Also a sound knowledge of the aircraft system to be tested and or calibrated is essential before attempting any tests. The procedures described herein are guidelines, and do not replace any specifications to the contrary by either the airframe or instrument manufacturer. Particular attention should be addressed to the following procedures to avoid erroneous test results or damage to any of the aircraft or Test Set instruments.
- (2) A Test Set valve is closed by clockwise rotation and opened by counter clockwise rotation.

CAUTION: DO NOT USE UNNECESSARY FORCE TO CLOSE ANY VALVE. POSITIVE STOP SPACERS HAVE BEEN INSTALLED PERMITTING FIRM CLOSING WITHOUT DAMAGING THE VALVE. EXCESSIVE FORCE CAN OVERCOME THE KNOB SET SCREW RESULTING IN VALVE DAMAGE.

2. PRESSURE / VACUUM SOURCE OPERATION

A. Using Hand Pumps

- (1) Verify that the **PRESSURE CONTROL** is fully closed.
- (2) Alternately raise and lower the handle of the **PRESSURE PUMP** several times.
- (3) The **PRESSURE TANK** gauge will indicate the pressure available for testing. Approximately 15 psi are required for testing.
- (4) Verify that the **VACUUM CONTROL** valve is fully closed.
- (5) Alternately raise and lower the handle of the **VACUUM PUMP** several times.
- (6) The **VACUUM TANK** gauge will indicate the vacuum available for testing. Approximately 20 in Hg. are required for testing.

B. Using An External Source

CAUTION: THE PRESSURE SOURCE SHOULD BE CLEAN, DRY, FILTERED AIR, OR PREFERABLY DRY NITROGEN. THE PRESSURE SOURCE MUST NOT EXCEED 20 PSI.

- (1) Verify that the **PRESSURE CONTROL** valve is fully closed.
- (2) Remove the vented plug from **EXTERNAL PRESSURE** port and connect to the proper pressure source. See **CAUTION** note above.
- (3) Raise the handle of the **PRESSURE PUMP**.
- (4) When the external pressure is applied, **PRESSURE TANK** gauge will indicate the pressure available for testing. **DO NOT EXCEED 20 PSI.**
- (5) Verify that the **VACUUM CONTROL** valve is fully closed.
- (6) Remove the vented plug from **EXTERNAL VACUUM** Port and connect to a suitable source of vacuum capable of at least 20 in. Hg. When the external vacuum is applied, the **VACUUM TANK** gauge will indicate the vacuum available for testing.

NOTE: The Barfield Model 2510-F Portable Pressure-Vacuum Pump will provide suitable pressure and or vacuum when used as an external source.

C. Using The Built In Electric Pump (H MODEL)

CAUTION: VERIFY THAT INTERNAL PUMP SWITCH IS IN THE OFF POSITION, AND THAT PRESSURE CONTROL AND VACUUM CONTROL VALVES ARE FULLY CLOSED.

NOTE: Although the internal pump is capable of continuous operation, it should be used only as required to maintain sufficient pressure or vacuum for the test being performed. Continuous pump operation will cause a gradual heat rise which can affect the accuracy of the calibration as recorded on instrument correction cards.

- (1) Connect the Test Set to 115 volt 60 Hz or 230 volt / 50 Hz supply, as applicable using appropriate power cable.
- (2) Set the INTERNAL PUMP SELECTOR valve to the PRESSURE position.

CAUTION: INTERNAL PUMP SELECTOR VALVE SHOULD ALWAYS BE IN EITHER THE PRESSURE OR VACUUM POSITION. DO NOT OPERATE WITH THE SELECTOR IN A "BETWEEN" POSITION (POINTED TOWARD THE CROSSBLEED CONTROL) TO AVOID AS SEVERE OVERHEATING OF THE PUMP.

- (3) Set INTERNAL PUMP switch to ON. PRESSURE TANK gauge will indicate the pressure available for testing. Approximately 15 psi are required

NOTE: The pressure relief of the internal pump is set at 15 psi.

- (4) Move the INTERNAL PUMP SELECTOR valve to the VACUUM position. The VACUUM TANK gauge will indicate the vacuum available for testing. Approximately 20 in Hg. are required.

NOTE: The INTERNAL PUMP SELECTOR valve may be changed from PRESSURE to VACUUM or vice versa at any time to replenish a tank supply pressures.

NOTE: Always verify PRESSURE CONTROL and VACUUM CONTROL valves are fully closed before changing INTERNAL PUMP SELECTOR valve.

NOTE: When the INTERNAL PUMP is switched OFF with either pressure or vacuum established in the reservoir tanks, it may not re-start when switched ON. Should this occur, momentarily change INTERNAL PUMP SELECTOR valve to the opposite position until the pump starts, then return to the desired operating position.

3. PREPARATION FOR TEST

A. Preliminary Setup

- (1) Verify that all tester switches are OFF, that PRESSURE / VACUUM control and VERTICAL SPEED valves, and are closed, and that PRESSURE / VACUUM VENT and CROSSBLEED valves, and are open.

Note: Steps (2) thru (5) below apply to the H model only.

- (2) Set INTERNAL PUMP SELECTOR VALVE to pressure position.
- (3) Connect tester line cord to supply.
- (4) Turn INTERNAL PUMP SWITCH to on. Verify that the PRESSURE TANK indicator reading increases to approximately 15 psi.
- (5) Move INTERNAL PUMP SELECTOR VALVE to vacuum position. Verify that the VACUUM TANK indicator reading to increases approximately 20 in Hg.

Note: The INTERNAL PUMP SELECTOR VALVE can be moved to the PRESSURE or VACUUM positions at any time to replenish the vacuum and / or pressure tanks, provided that PRESSURE / VACUUM CONTROL VALVES and are closed. Leave this valve in either position to avoid overheat of the pump that occurs when the valve is in-between positions.

6. If external vacuum/pressure source are required, refer to section for instructions.
7. Set ALTIMETER setting to 29.92 in Hg.

4. TESTER LEAK CHECKS

A. Pitot

1. Close CROSSBLEED and PRESSURE VENT valves fully and check INTERNAL PUMP SELECTOR switch is in PRESSURE position.
2. Connect hose that is going to be used for testing to the PRESSURE PORT and cap the other end. Verify that connections are tight and use teflon tape to prevent leaks.
3. Verify that PRESSURE TANK indicator reads approximately 15 psi. Use manual or electric pumps (H Model) as necessary.
4. Open PRESSURE CONTROL VALVE slowly and observe tester AIRSPEED indicator shows increasing airspeed. When indicator reads approximately 400 KTS, close PRESSURE CONTROL VALVE.
5. Observe tester AIRSPEED indicator for one minute. Verify that indicated airspeed does not decrease, more than 2 knots.
6. Slowly open PRESSURE VENT valve AIRSPEED indicator will show decreasing airspeed. Allow airspeed to bleed off until AIRSPEED indicator reads 20-40 knots, then close PRESSURE VENT valve.
7. Open CROSSBLEED valve fully.

B. Static

1. Connect hose that is going to be used for testing to the VACUUM port and cap the other end. Verify that connections are tight and use teflon tape to prevent leaks.
2. Verify CROSSBLEED valve is fully open and that VACUUM TANK pressure indicator reads at least 20 in Hg. INTERNAL PUMP SELECTOR switch should be set to VACUUM position (H Model).
3. Verify that PRESSURE CONTROL, PRESSURE VENT, and VACUUM VENT valves are closed and open VERTICAL SPEED valve fully.
4. Slowly open VACUUM CONTROL valve while observing VERTICAL SPEED indicator. Maintain approximately 4000 FPM rate of change until tester ALTIMETER indicates approximately 20000 ft., then close VACUUM CONTROL valve. Adjust VACUUM CONTROL valve as required to maintain climb rate.

5. Observe ALTIMETER and check that altitude does not change by more than 100 ft. after one minute.
6. Slowly open PRESSURE VENT valve. Observe VERTICAL SPEED indicator to maintain approximately 4000 FPM rate of change until ALTIMETER indicates approximately field elevation and VERTICAL SPEED indicator reads 0. Adjust PRESSURE VENT valve as required to maintain this rate.
7. Close VERTICAL SPEED valve and open VACUUM VENT valve.

5. STATIC SYSTEM TESTS

A. Preliminary Setup

1. Verify that tester has been leaks checked, and preparation for tests instructions are completed before proceeding.
2. Remove cap from aircraft end of static hose and connect applicable static port adapter. Seal connection with teflon tape.
3. Connect static port adapter to aircraft per maintenance manual instructions.

Note: Some aircraft have more than one static port associated with a given static system. Make sure that other ports in the system being tested are sealed before proceeding.

4. Verify that **EXTERNAL VACUUM** port is vented unless external vacuum source is used. Refer to section 2.A for instructions on how to use external vacuum source or hand pumps. If internal pumps are used (H Model only), keep **INTERNAL PUMP SELECTOR** switch in vacuum position.
5. Open **CROSSBLEED** valve and **VERTICAL SPEED** valve fully.
6. Verify that **VACUUM VENT** valve and **PRESSURE VENT** valve are closed.

B. Test

- (1) If desired altitude is below field elevation, open slowly the **PRESSURE CONTROL** valve until desired altitude is indicated by the tester **ALTIMETER**. If desired altitude is above field elevation, use the **VACUUM CONTROL** valve instead of the **PRESSURE CONTROL** valve.

CAUTION: Watch for negative airspeed indications and be very careful while approaching -1000 ft. pressure altitude. Severe damage to tester and cockpit instruments may result from excessive rates of change of altitude / airspeed.

Note: Monitor the tester VERTICAL SPEED INDICATOR while adjusting either the PRESSURE or VACUUM CONTROL valves. Do not exceed a rate equivalent to 2/3 of the maximum rate displayed on the aircraft vertical airspeed indicator.

Note: If overshoot occurs, adjust slightly the PRESSURE / VACUUM CONTROL and PRESSURE VENT valve until desired altitude is achieved.

Note: Use tester Altimeter Calibration Chart where exact altitudes are required.

Note: Tap tester altimeter periodically to avoid friction errors.

- (2) For leak tests on the aircraft, set desired altitude per step (1) above, and then close applicable control valve. Perform leak check as specified in the aircraft maintenance manual; if there are no specifications, wait 2 minutes after closing tester control valve and verify that indicated altitude does not change by more than 100 ft. in one minute.
- (3) For altimeter and VSI calibration checks, set desired altitude per step (1) above, being careful not to overshoot desired settings. Use calibration chart to correct tester instrument indicators.
- (4) To return static system to ambient, close VACUUM CONTROL valve and open slowly the PRESSURE VENT valve, monitoring the VERTICAL SPEED indicator to insure that a rate equivalent to 2/3 of the maximum rate displayed on the aircraft vertical speed indicator is not exceeded .
- (5) When field elevation altitude is reached, VERTICAL SPEED indicator will read zero. Open the VACUUM VENT valve and close the VERTICAL SPEED valve fully.

6. PITOT SYSTEM TESTS

A. Preliminary Setup

- (1) Verify that tester has been leak checked and preparation for test instructions are completed before proceeding.
- (2) Remove cap from aircraft end of Pitot hose and connect applicable pitot tube adapter. Seal connections with teflon tape.
- (3) Connect pitot tube adapter to aircraft per maintenance manual instructions.

Note: Make sure that pitot tube adapter connection is properly sealed before proceeding.

- (4) Verify EXTERNAL PRESSURE port is vented unless external pressure source is used. Refer to section 2.A for instructions on how to use external pressure source or hand pumps. If internal pumps are used (H Model) leave INTERNAL PUMP SELECTOR switch in PRESSURE position.
- (5) Close CROSSBLEED valve (14) fully.
- (6) Verify that PRESSURE VENT valve is closed and VACUUM VENT valve is fully open.

B. Test

- (1) Open slowly the PRESSURE CONTROL valve until desired airspeed is indicated in the tester AIRSPEED indicator.

Note: If overshoot occurs, open slightly the PRESSURE CONTROL VENT valve and until desired airspeed is achieved.

Note: Use tester Airspeed Calibration Chart when exact airspeeds are required.

Note: Tap airspeed indicator on tester periodically to avoid potential friction errors.

- (2) For leak tests on the aircraft, set desired airspeed per step (1) above, and then close PRESSURE CONTROL valve. Perform leak check as specified in the aircraft maintenance manual; if there are no specifications, wait 2 minutes after closing the PRESSURE CONTROL valve; and verify that indicated airspeed does not change more than 2 knots.

- (3) For airspeed calibration checks, set desired airspeed per step (1) above. Use calibration charts to correct tester instrument indications
- (4) To return Pitot system to ambient, close **PRESSURE CONTROL** valve and open slowly the **PRESSURE VENT** valve until tester **AIRSPEED INDICATOR** reads less than 40 knots.
- (5) Open **CROSSBLEED** valve fully.

7. COMBINED PITOT / STATIC SYSTEM TESTS

A. Preliminary Setup

- (1) Verify that tester has been leak checked and preparation for test instructions have been completed before proceeding.
- (2) Remove caps from pitot and static hoses, and connect applicable adapters.
- (3) Connect pitot adapter to aircraft pitot tube per maintenance manual instructions. Verify that connections are properly sealed with teflon tape.
- (4) Connect static adapter to aircraft static port per maintenance manual instructions.

Note: Some aircraft have more than one static port associated with a given system. Make sure that connection are properly sealed, and that other parts associated with the system are sealed with tape before proceeding.

- (5) Verify CROSSBLEED valve is fully open; and that PRESSURE CONTROL, VACUUM CONTROL, PRESSURE VENT, and VACUUM VENT valves are closed.
- (6) Set INTERNAL PUMP SELECTOR switch to vacuum. (H Model only)
- (7) Verify that VERTICAL SPEED valve is fully open.

B. Test

- (1) Slowly open VACUUM CONTROL valve while observing the VERTICAL SPEED indicator and maintain a rate equivalent to 2/3 of the aircraft Vertical Speed Indicator maximum reading until desired altitude is achieved. Adjust VACUUM CONTROL and PRESSURE VENT valve as required to maintain rate of climb and set desired altitude, then close both valves.
- (2) Close CROSSBLEED valve fully.

- (3) Open slowly the PRESSURE CONTROL valve and observe the AIRSPEED INDICATOR shows increase in reading. When desired airspeed is achieved, close the PRESSURE CONTROL valve. If overshoot occurs, close the PRESSURE CONTROL valve, and slightly open the CROSSBLEED valve to equalize the pressures. When desired airspeed is achieved, close the CROSSBLEED valve.

Note: The altitude displayed on the tester ALTIMETER may drop slightly after the CROSSBLEED valve is opened. It may be necessary to adjust simultaneously the CROSSBLEED and PRESSURE / VACUUM control valves to achieve the desired altitude / airspeed combination.

- (4) Perform tests as specified in the aircraft maintenance manual.
- (5) After tests are completed, slowly open the CROSSBLEED valve to its full open position. After AIRSPEED indicator shows airspeed less than 50 KTS, open slowly the PRESSURE VENT valve to bring the system back to ambient pressure.

Note: Do not exceed rate equivalent to 2/3 of maximum indication on the aircraft rate of climb indicator.

- (6) After field elevation altitude is reached, VERTICAL SPEED indicator will read zero. Open VACUUM VENT valve and close the VERTICAL SPEED valve fully.

8. MACHMETER TEST

Note: Test limited by Test Set Airspeed range.

A. Test Procedure

Refer to Table 1 and establish respective altitude and airspeed combinations by the following procedures as described in Section 7.

ALTITUDE (IN FEET)	AIRSPEED (IN KNOTS)							
	(FROM NTIS #62-71396)							
	MACH NO.							
	.50	.60	.70	.75	.80	.82	.85	.90
10K	277	334	391	420	449	---	---	---
15K	247	298	350	376	403	414	429	---
20K	228	275	324	348	373	383	398	424
25K	205	248	292	315	338	347	361	384
29K	188	228	269	289	311	319	332	354
33K	172	207	246	265	285	292	304	324
37K	157	190	224	242	260	267	278	297
41K	142	173	204	220	237	243	253	277
45K	---	157	186	201	216	222	231	246
49K	---	143	169	183	196	202	210	225
51K	---	---	161	174	187	193	201	214

AIRSPEED (IN KNOTS)
 VERSUS MACH NUMBER
 MACHMETER TEST TABLE

Table 1

57-101-00165/168/169

FOR REFERENCE ONLY

9. ENGINE PRESSURE RATIO (EPR) TEST

Note: Test limited by Test Set Airspeed range.

A. Test Procedure

- (1) Connect PRESSURE PORT to Pt7 (Hi) port of E.P.R. to be tested.
- (2) Connect VACUUM PORT to Pt2 (Lo) port of E.P.R. to be tested.
- (3) Refer to Table 2 and establish respective altitude and airspeed combinations by following procedures as described in Section 7.

ENG PRESS RATIO	AIRSPEED (KNOTS) Pt7 (Hi) PORT	ALTITUDE (FEET) Pt2 (Lo) PORT
3.4	650	25,870
3.4	546	35,000
3.0	650	21,650
3.0	504	35,000
2.5	650	14,690
2.5	534	25,870
2.5	444	35,000
2.0	650	4,210
2.0	500	20,000
2.0	369	35,000
1.5	478	5,000
1.5	365	20,000
1.5	265	35,000

ENGINE PRESSURE RATIO TEST TABLE

Table 2

10. MANIFOLD PRESSURE GAUGE TEST

A. Test Procedure

- (1) Plug or Cap PRESSURE PORT.
- (2) Connect VACUUM PORT to manifold gauge to be tested.
- (3) Close all Test Set valves then open CROSSBLEED CONTROL fully and leave open for the remainder of this procedure.
- (4) Verify that ALTIMETER is set at 29.92 IN (1013.3 mb).
- (5) Operate VACUUM PUMP (H) and PRESSURE PUMP as required.
- (6) Refer to Table 3 for respective altitude and In. Hg. manifold pressure readings.

MANIFOLD PRESS. INCHES OF MERCURY	ALTITUDE (FEET)
31	-935
30	- 75
29	+860
28	1,825
27	2,815
26	3,835
25	4,890
20	10,730
15	17,905
10	27,375

MANIFOLD PRESSURE VERSUS ALTITUDE

Table 3

- (7) Gradually open **PRESSURE CONTROL** for test points below field elevation and **VACUUM CONTROL** for test points above field elevation.
- (8) To return system to ambient, close **PRESSURE** and **VACUUM CONTROL** and bleed system with **PRESSURE VENT** valve.

11. PRESSURE TESTS

NOTE: The following provides tests in the range of 0-12 psi, 0-25 in. Hg, or 1-340 in. H₂O.

A. Test Procedure

Refer to Table 4.

- (1) Connect **PRESSURE PORT** to pressure unit to be tested. (**VACUUM PORT** is not used).
- (2) Close all valves, then open **VACUUM VENT** valve fully and leave open for the remainder of this procedure.
- (3) Develop pressure as required for tests to be performed.
- (4) Gradually open **PRESSURE CONTROL** valve to establish desired reading on airspeed for equivalent pressure in Table 1.
- (5) To lower airspeed reading or to return to ambient, gradually open **PRESSURE VENT** valve.

12. VACUUM TESTS

NOTE: The following provides tests in the range of 0-12 psi, 0-25 in. Hg or 1-340 in. H₂O.

A. Test Procedure

Refer to Table 4.

- (1) Connect **VACUUM PORT** to vacuum unit to be tested. (**PRESSURE PORT** is not used.)
- (2) Close all valves, then open **PRESSURE VENT** valve fully and leave open for the remainder of this procedure.
- (3) Develop vacuum as required for tests to be performed.
- (4) Gradually open **VACUUM CONTROL** valve to establish airspeed equivalents for desired reading on airspeed for equivalent vacuum in Table 1.
- (5) To lower, airspeed reading or to return to ambient, gradually open **VACUUM VENT** valve.

INCHES WATER	INCHES MERCURY	POUNDS SQ. IN.	AIRSPED (KNOTS)	INCHES WATER	INCHES MERCURY	POUNDS SQ. IN.	AIRSPED (KNOTS)
1.000	0.073	0.036	39	55.416	4.072	2.000	285
2.000	0.146	0.072	55	68.045	5.000	2.466	314
3.000	0.220	0.108	68	81.654	6.000	2.947	342
4.000	0.294	0.144	78	83.124	6.108	3.000	355
5.000	0.367	0.180	87	95.263	7.000	3.438	368
6.000	0.441	0.216	96	108.872	8.000	3.929	391
7.000	0.514	0.252	103	110.832	8.144	4.000	395
8.000	0.587	0.288	110	122.481	9.000	4.420	413
9.000	0.661	0.325	117	136.090	10.000	4.912	433
10.000	0.734	0.361	123	138.540	10.180	5.000	437
12.000	0.881	0.433	135	163.308	12.000	5.954	470
13.609	1.000	0.481	144	166.248	12.216	6.000	474
14.000	1.028	0.505	146	190.526	14.000	6.876	504
16.000	1.175	0.577	155	193.955	14.252	7.000	508
18.000	1.322	0.649	165	217.744	16.000	7.859	534
20.000	1.468	0.721	174	221.663	16.288	8.000	538
25.000	1.836	0.901	194	244.962	18.000	8.841	561
27.218	2.000	0.982	203	249.371	18.324	9.000	565
27.707	2.036	1.000	204	272.180	20.000	9.823	587
30.000	2.202	1.082	212	277.079	20.360	10.000	591
35.000	2.570	1.262	229	299.398	22.000	10.806	611
40.000	2.937	1.443	244	304.787	22.396	11.000	615
40.827	3.000	1.473	246	326.616	24.000	11.788	633
45.000	3.304	1.623	258	332.495	24.432	12.000	638
50.000	3.671	1.803	271	340.225	25.000	12.279	644
54.436	4.000	1.965	283				

AIRSPED EQUIVALENT (KNOTS) FOR DIFFERENTIAL
PRESSURE/VACUUM

Table 4

57-101-00165/168/169

FOR REFERENCE ONLY

1-2
Page 27
March 12/91

13. SHUTDOWN PROCEDURES

A. Test Set

- (1) Open VACUUM VENT, CROSSBLEED and, PRESSURE VENT valves fully.
- (2) Close PRESSURE CONTROL, VACUUM CONTROL, and VERTICAL SPEED valves fully.
- (3) Turn all tester switches to OFF (H Model), disconnect aircraft hose and cap the PITOT and STATIC ports of the test set.

B. Aircraft

- (1) Remove all adapters and sealing tapes from aircraft pitot / static ports.
- (2) Install applicable cover and strumitis required by the aircraft maintenance manual.

SHIPPING

1. RECEIVING

No special unpacking procedures are necessary. It is recommended that the factory shipping container and packing materials be retained should it become necessary, for any reason to reship the Test Set.

It is also recommended that the Test Set be carefully inspected for damage. If damaged, immediately notify the carrier and the manufacturer.

2. SHIPPING

It is of the utmost importance that the PRESSURE VENT, CROSSBLEED CONTROL and VACUUM VENT valves be fully opened for shipping. All other valves should be closed. If the Test Set is not configured in this fashion damage to the instruments may result. Also insure that no loose items such as fittings or tools are left inside the Test Set which could prove harmful in shipping.

57-101-00165/168/169

FOR REFERENCE ONLY

1-3
Page 1

March 12/91

THIS PAGE INTENTIONALLY LEFT BLANK

STORAGE

1. PROCEDURE

- A. Insure PRESSURE TANK and VACUUM TANK are at ambient.
- B. Insure PRESSURE VENT, VACUUM VENT and CROSSBLEED CONTROL valves are fully open.
- C. Insure PRESSURE CONTROL, VACUUM CONTROL and VERTICAL SPEED valves are closed.
- D. Place a four ounce bag of desiccant inside the case.
- E. Close and latch the lid.
- F. Store in a cool dry place.

THIS PAGE INTENTIONALLY LEFT BLANK

SERVICING

1. PERIODIC INSPECTION

The following maintenance and lubrication attention should be performed during the following inspection periods.

PERIOD	REQUIRED INSPECTION
EACH USE	LEAKAGE TEST: SECTION 1-2 PROCEDURE 4. INTERNAL PUMP (H MODEL): SECTION 1-2 PROCEDURE 3.
6 MONTHS	CHECK ALTIMETER FOR SCALE ERROR AND HYSTERESIS AT ROOM TEMPERATURE PER SECTION 2-1 PROCEDURE 3. CHECK AIRSPEED FOR SCALE ERROR AT ROOM TEMPERATURE PER SECTION 2-1 PROCEDURE 4. CHECK VERTICAL SPEED INDICATOR PER SECTION 2-1 PROCEDURE 5. REWRITE CALIBRATION CARDS AS REQUIRED
<u>NOTE:</u> IF TEST SET IS TO BE USED FOR COMPLIANCE WITH F.A.R. 91.171 AND PART 43, APPENDIX E, "ALTIMETER SYSTEM TESTS AND INSPECTIONS," REFER TO F.A.A. ADVISORY CIRCULAR AC 43-203B (OR SUBSEQUENT) FOR APPROVED INSPECTION INTERVALS AND PROCEDURES.	
12 MONTHS	ALL OF THE PRECEDING PLUS: CHECK PRESSURE AND VACUUM GAUGES FOR ACCURACY AND FRICTION. EITHER GAUGE ACCURACY IS 3% OF SCALE RANGE FOR UPPER AND LOWER THIRD, 2% FOR THE CENTER THIRD. FRICTION TOLERANCE IS ONE SCALE DIVISION. CHECK VACUUM AND PRESSURE HAND PUMPS FOR LEAKAGE AND CAPACITY.

REQUIRED PERIODIC INSPECTION
Table 1

2. INSTRUMENT RECERTIFICATION

Make certain that instrument correction cards are revised as required and that calibration dates for recertification periods are recorded.

Calibration cards are based on tests performed with instruments mounted vertically (face up) and at a temperature of 75°F (25°C). Change of attitude of more than 30° from level and or a temperature difference of more than 15°F (9°C) may effect the precise calibration accuracy.



1811D INSTRUCTION MANUAL

APPENDIX

BARFIELD INC. ENGINEERING SPECIFICATIONS

Note: For information on compliance with FAR 91-411, refer to Barfield document, 60-101-00150.

SECTION 1: ALTIMETER

SECTION 2: AIRSPEED INDICATOR

SECTION 3: VERTICAL SPEED INDICATOR

THIS PAGE INTENTIONALLY LEFT BLANK



1811D INSTRUCTION MANUAL

SECTION 1. ALTIMETER

The following engineering specification (Document No 23-338-00001, dated 7/24/91) details the performance requirements of the pressure sensitive altimeters used by Barfield, Inc. to manufacture ground support test equipment.

THIS PAGE INTENTIONALLY LEFT BLANK

- - - - - ENGINEERING SPECIFICATION - - - - -

Title: Altimeter, Ground Support Equipment		Barfield Instrument Corp. 4101 N.W. 29 Street Miami, FL. 33142
DRAWING NO: 23-338-00001		Page 1 of 5

REV	DATE	COMMENT
A	12/19/89	Initial Release
B	07/24/91	Addition of Dual Baro 35k & 50k Ft United Altimeter, P/N 59TD & 5934AD-1 respectively
<p>JUN 14 1999</p> <p>THIS DOCUMENT IS PROPRIETARY INFORMATION OF BARFIELD, INC. IS PROTECTED BY COPYRIGHT, AND SHALL NOT BE DISCLOSED TO ANY PERSON OR PARTY WITHOUT THE EXPRESS WRITTEN CONSENT OF THE PROPRIETOR. THIS NOTICE MUST BE MARKED ON ALL PARTIAL AND FULL REPRODUCTIONS.</p>		
DRAWN: <i>A. Eney</i>		CHECKED: J. ARMAS
APPROVED: <i>[Signature]</i> 8/6/91		

- - - - - ENGINEERING SPECIFICATION - - - - -	
Title: Altimeter, Minimum Use Specification	Barfield Instrument Corp. 4101 N.W. 29 Street Miami, FL. 33142
DRAWING NO: 23-338-00001	Page 2 of 5

1. Purpose: To specify performance requirements for Pressure Sensitive Altimeters for use in B.I.C. manufactured ground support test equipment.

2. Scope: This PRODUCT STANDARD SPECIFICATION covers two basic types of instruments as follows:

TYPE I - Range 35,000 ft. Barometric Pressure. Scale range at least 28.1 - 30.99 inches of Mercury (946-1049 millibars). May include markers working in conjunction with the Barometric Pressure Scale to indicate pressure - altitude.

TYPE II - Range 50,000 ft. Barometric Pressure. Scale range at least 28.1 - 30.99 inches of Mercury (946-1049 millibars). May include markers working in conjunction with Barometric Pressure Scale to indicate pressure - altitude.

3. Identification: All units regardless of origin of manufacture are to be identified by B.I.C. assigned part numbers as follows:

B.I.C. P/N	FG.	P/N	TYPE NO.	RANGE
124-00001 in.Hg Baro	UNITED KOLLSMAN AEROSONIC	5950 671, 1845 101750-01710 101735-01710	II	50,000 FT
124-00002 in.Hg Baro	KOLLSMAN	D22061	II	55,000 FT
124-00003 Dual Baro	AEROSONIC UNITED	101735-01495 * 5950	II	50,000 FT
124-00004 in.Hg Baro	UNITED UNITED AEROSONIC	5934A-1 5934PA-1 101735-01455	I	35,000 FT
124-00005 Dual Baro in.Hg/mb	UNITED AEROSONIC UNITED	5934PAD-1 101735-01495 5934AD-1	I	35,000 FT
124-00006 mb Baro	KOLLSMAN AEROSONIC UNITED	671 101735-01455 5950	II	50,000 FT

**BARFIELD INC
FOR REFERENCE ONLY**

- - - - - ENGINEERING SPECIFICATION - - - - -	
Title: Altimeter, Minimum Use Specification	Barfield Instrument Corp. 4101 N.W. 29 Street Miami, FL. 33142
DRAWING NO: 23-338-00001	Page 3 of 5

B.I.C. P/N	FG.	P/N	TYPE NO.	RANGE
124-00007 mb Baro	UNITED UNITED KOLLSMAN AEROSONIC	5934AM-1 5934PAM-1 671CP 101735-01455	I	35,000 FT
124-00008	UNITED AEROSONIC UNITED	5950 101735-01455 * 591D	II	50,000 FT (OXYGEN ONLY)

Note: "*" indicates service only, not available.4. Test Conditions:
 Unless otherwise specified, all tests shall be made with the instrument mounted in the horizontal (Face UP) position.

5. Performance Requirements:

All units are required to meet the following performance requirements before installation in any ground support test equipment.

5.1 Case Leak:

A pressure equivalent to 18,000 ft. within the case shall not result in leakage exceeding 20 ft (100 ft when installed in Test Set) per minute.

5.2 Friction:

The instrument shall be tested for friction at varied readings of the scale. The instrument shall be subjected to a steady rate of decreasing pressure equivalent to about 750 ft per minute. The change in reading of the pointers due to vibrating the instrument at each of the altitudes specified in table-1 is to be recorded as friction and shall not exceed the tolerances listed.

ALTITUDE (FEET)	TOLERANCE (FEET ±)
1,000	70
2,000	70
3,000	70
5,000	80
10,000	90
15,000	100
20,000	125
25,000	150
30,000	175
35,000	200
40,000	250
50,000	400

Table-1 FRICTION
 BARFIELD INC
 FOR REFERENCE ONLY

- - - - - ENGINEERING SPECIFICATION - - - - -	
Title: Altimeter, Minimum Use Specification	Barfield Instrument Corp. 4101 N.W. 29 Street Miami, FL. 33142
DRAWING NO: 23-338-00001	Page 4 of 5

5.3 Hysteresis:

Not more than 15 minutes after the altimeter has been first subjected to the pressure corresponding to the upper limit of the scale (ref. table-2 or 3 as applicable), test point -2- ,the pressure shall be increased at a rate corresponding to a decrease in altitude of approximately 3,000 feet per minute until the pressure corresponding to test point -3- is reached. Within 10 seconds the instrument shall indicate within 100 feet of the test reading. The altimeter shall remain at this pressure for at least 5 minutes but not more than 15 minutes before the test reading is taken. After the reading has been taken, the pressure shall be further increased at the above rate until the pressure corresponding to test point -4- is reached. The altimeter shall remain at this pressure for at least one minute but not more than 10 minutes before the test reading is taken. After the reading has been taken, the pressure shall be further increased at the above rate until atmospheric pressure is reached. The reading of the altimeter at either of the two test points shall not differ from the reading of the altimeter for the corresponding altitude in the scale error test by more than the tolerance specified in the corresponding table. For a TYPE-I instrument use Table-2, TYPE-II use Table-3.

TEST POINT	ELEVATION (FEET)	TIME Min/Max	ALLOWABLE ERROR (FT)
1	0	---	---
2	35,000	--/15	---
3	18,000	5/15	70
4	14,000	1/10	70
* 5	0	-/5	50

TABLE 2 HYSTERESIS / - TYPE-I

TEST POINT	ELEVATION (FEET)	TIME Min/Max	ALLOWABLE ERROR (FT)
1	0	---	---
2	50,000	--/15	---
3	25,000	5/15	150 (100)
4	20,000	1/10	150 (100)
* 5	0	-/5	60 (50)

TABLE 3 HYSTERESIS - TYPE -II

- Note:
- a) * Test point 5 is the "After Effect" specification.
 - b) The values in Table-3 enclosed in "■" are applicable against the 124-00002 instrument.

5.4 After Effect:

Not more than 5 minutes after the completion of the hysteresis test, the pointers shall have returned to their original reading, corrected for any change in atmospheric pressure to within the tolerance specified by test point -5- in the corresponding table. For a TYPE-I instrument use Table-2, TYPE-II use Table-3.

- - - - - ENGINEERING SPECIFICATION - - - - -	
Title: Altimeter, Minimum Use Specification	Barfield Instrument Corp. 4101 N.W. 29 Street Miami, FL. 33142
DRAWING NO: 23-338-00001	Page 5 of 5

5.5 Scale Error:

For a period of not less than twelve hours prior to this test the altimeter shall not have been operated at pressures other than ambient. The barometric scale shall be set at 29.92 inches of mercury and the scale error recorded. Without changing the baro setting, the altimeter shall be subject successively to the pressure specified in Table-4. The reduction in pressure shall be made at a rate not in excess of 20,000 feet per minute to within approximately 2,000 feet of the test point. The test point shall be approached at a rate compatible with the test equipment. The altimeter shall remain at the pressure corresponding to each test point for at least 1 minute but no more than 10 minutes before a reading is taken. The error at all test points shall not exceed the tolerances specified in Table-4 or Table-5 as applicable.

ALTITUDE (FEET)	ALTIMETER ERROR ±
-1,000	40
0	40
500	40
1,000	40
1,500	50
2,000	60
3,000	60
4,000	70
6,000	80
8,000	120
10,000	160
12,000	200
14,000	225
16,000	240
18,000	275
20,000	300
22,000	340
25,000	375
30,000	450
35,000	525
40,000	600
45,000	675
50,000	750

Table-4 Scale Error

ALTITUDE (FEET)	ALTIMETER ERROR ±
-1,000	20
0	20
500	20
1,000	20
1,500	25
2,000	30
3,000	30
4,000	35
6,000	40
8,000	60
10,000	80
12,000	90
14,000	100
16,000	110
18,000	120
20,000	130
22,000	140
25,000	155
30,000	180
35,000	205
40,000	230
45,000	255
50,000	280
55,000	600

Table-5 Scale Error

Note: Table-4 Applicable against: 124-00001, 124-00003, 124-00004, 124-00005, 124-00006, 124-00007, 124-00008

Table-5 Applicable against: 124-00002
BARFIELD INC
FOR REFERENCE ONLY

THIS PAGE INTENTIONALLY LEFT BLANK



1811D INSTRUCTION MANUAL

SECTION 2. AIRSPEED INDICATOR

The following engineering specification (*Barfield Document No. 23-336-A0025, dated 1/8/90*) details the performance requirements of the pitot static pressure type airspeed indicators used by Barfield, Inc. to manufacture ground support test equipment.

THIS PAGE INTENTIONALLY LEFT BLANK

----- ENGINEERING SPECIFICATION -----

Title: Airspeed, Ground Support Equipment		Barfield Instrument Corp. 4101 N.W. 29 Street Miami, FL. 33142
DRAWING NO: 23-336-A0025		Page 1 of 5

REV	DATE	COMMENT
A	01/08/90	Initial Release
<p>JUN 14 1999</p> <p>THIS DOCUMENT IS PROPRIETARY INFORMATION OF BARFIELD, INC. IS PROTECTED BY COPYRIGHT, AND SHALL NOT BE DISCLOSED TO ANY PERSON OR PARTY WITHOUT THE EXPRESS WRITTEN CONSENT OF THE PROPRIETOR. THIS NOTICE MUST BE MARKED ON ALL PARTIAL AND FULL REPRODUCTIONS.</p>		
DRAWN: <i>P. Egan</i>		CHECKED: <i>[Signature]</i>
		APPROVED: <i>[Signature]</i> 2/12/90

**BARFIELD INC
FOR REFERENCE ONLY**

- - - - - ENGINEERING SPECIFICATION - - - - -	
Title: Airspeed, Ground Support Equipment	Barfield Instrument Corp. 4101 N.W. 29 Street Miami, FL. 33142
DRAWING NO: 23-336-A0025	Page 2 of 5

1. **Purpose:**
To specify performance requirements for Pitot Static Pressure Type of Airspeed Indicators for use in B.I.C. Manufactured ground support test equipment.

2. **Scope:**
This Product STANDARD SPECIFICATION covers two (2) basic types of airspeed indicators with indication range essentially as follows:

- TYPE I - 1 Revolution
- TYPE II - 7 Revolutions

3. **Identification:**
All units regardless of origin of manufacture are to be identified by B.I.C. assigned part numbers as follows:

B.I.C. P/N	MFG. P/N	TYPE NO.	RANGE
336-00001R	1432	II	50 - 650 Knots
336-00001	S65KS	II	50 - 650 Knots
336-00004	8040	I	60 - 420 Knots
336-00005	8025B.477	I	40 - 200 Knots
336-00006	S25KAW	I	20 - 250 Knots

4. **Test Conditions:**
Unless otherwise specified, all tests shall be made with the instrument mounted in the horizontal (Face UP) position.

5. **Performance Requirements:**
All units are required to meet the following performance requirements before installation in any ground support test equipment.

5.1 **Friction:**
The instrument shall be tested for friction at approximately four essentially equal scale intervals. The pressure shall be brought up to the desired reading and then held constant while two readings are taken. The first reading being taken before the instrument is vibrated, and the second one after the instrument is vibrated. The difference between any two readings shall not exceed any of the tolerances listed in the calibration specifications.

5.2 **Leak:**
With both the pitot pressure and static pressure connections simultaneously evacuated to 15 inches of Mercury, the leakage shall not cause more than 0.4 inch of mercury pressure drop during a 10 second period.

- - - - - ENGINEERING SPECIFICATION - - - - -	
Title: Airspeed, Ground Support Equipment	Barfield Instrument Corp. 4101 N.W. 29 Street Miami, FL. 33142
DRAWING NO: 23-336-A0025	Page 3 of 5

5.3 Vibration:

With pressure applied, sufficient to give half scale deflection, the instrument shall be subjected to vibrations of all frequencies within the appropriate ranges specified.

5.4 Pointer Position:

The position of the pointer without any pressure applied shall rest on the lowest airspeed on the dial with the exception of P/N's 336-00001, 336-00001R and 336-00004. The 336-00001 & .1R units pointer should rest between 15-45 knots. The 336-00004 unit pointer position should rest at 350° ± 5° position; (12 o'clock being the 360° position.)

6. Calibration and Test:

All units shall be tested to the following specifications.

6.1 P/N 336-00001&1R

READING	TOLERANCE	READING	TOLERANCE
50	± 5.0	220	± 4.0
60	± 3.0	240	± 4.0
70	± 3.0	260	± 4.0
80	± 3.0	280	± 4.0
90	± 3.0	300	± 4.0
100	± 3.0	320	± 4.0
110	± 3.0	340	± 4.0
120	± 3.0	360	± 5.0
130	± 3.0	380	± 5.0
140	± 3.0	400	± 5.0
150	± 3.5	450	± 5.0
160	± 3.5	500	± 5.0
170	± 3.5	550	± 5.0
180	± 4.0	600	± 5.0
190	± 4.0	650	± 5.0
200	± 4.0	700	± 5.0

- - - - - ENGINEERING SPECIFICATION - - - - -	
Title: Airspeed, Ground Support Equipment	Barfield Instrument Corp. 4101 N.W. 29 Street Miami, FL. 33142
DRAWING NO: 23-336-A0025	Page 4 of 5

6.2 P/N 336-00004

READING	TOLERANCE	READING	TOLERANCE
60 Knots	± 3.0	180	± 4.0
70	± 3.0	190	± 4.0
80	± 3.0	200	± 5.0
90	± 3.0	220	± 5.0
100	± 3.0	240	± 5.0
110	± 3.0	260	± 5.0
120	± 3.0	280	± 5.0
130	± 3.0	300	± 5.0
140	± 3.0	320	± 5.0
150	± 3.5	340	± 5.0
160	± 3.5	360	± 5.0
170	± 3.5	400	± 5.0
		420	± 5.0

6.3 P/N 336-00005

READING	TOLERANCE
20	± 5.0
30	± 5.0
40	± 3.5
50	± 3.0
60	± 3.0
70	± 3.0
80	± 3.0
90	± 3.0
100	± 3.0
110	± 3.0
120	± 5.0
130	± 5.0
140	± 5.0
150	± 5.0
160	± 5.0
170	± 5.0
180	± 5.0
190	± 5.0
200	± 5.0

- - - - - ENGINEERING SPECIFICATION - - - - -	
Title: Airspeed, Ground Support Equipment	Barfield Instrument Corp. 4101 N.W. 29 Street Miami, FL. 33142
DRAWING NO: 23-336-A0025	Page 5 of 5

6.4 P/N 336-00006

READING	TOLERANCE	READING	TOLERANCE
20	± 5.0	140	± 4.0
30	± 5.0	150	± 4.0
40	± 3.5	160	± 4.0
50	± 3.0	170	± 4.0
60	± 3.0	180	± 4.0
70	± 3.0	190	± 4.0
80	± 3.0	200	± 4.0
90	± 3.0	210	± 4.0
100	± 3.0	220	± 4.0
110	± 3.0	230	± 4.0
120	± 3.0	240	± 4.0
130	± 3.0	250	± 4.0

THIS PAGE INTENTIONALLY LEFT BLANK



1811D INSTRUCTION MANUAL

SECTION 3. VERTICAL SPEED INDICATOR

The following engineering specification (Document 23-337-A0025 dated 1/8/90) details performance requirements of the pressure actuated vertical speed indicators used by Barfield, Inc. to manufacture ground support test equipment.

THIS PAGE INTENTIONALLY LEFT BLANK

- - - - - ENGINEERING SPECIFICATION - - - - -	
Title: Vertical Speed Indicator Ground Support Equipment	Barfield Instrument Corp. 4101 N.W. 29 Street Miami, FL. 33142
DRAWING NO: 23-337-A0025	Page 1 of 4

REV	DATE	COMMENT
A	01/08/90	Initial Release
<p>JUN 14 1999</p> <p>THIS DOCUMENT IS PROPRIETARY INFORMATION OF BARFIELD, INC. IS PROTECTED BY COPYRIGHT, AND SHALL NOT BE DISCLOSED TO ANY PERSON OR PARTY WITHOUT THE EXPRESS WRITTEN CONSENT OF THE PROPRIETOR. THIS NOTICE MUST BE MARKED ON ALL PARTIAL AND FULL REPRODUCTIONS.</p>		
DRAWN: <i>C. Eney</i>		CHECKED: <i>M. C. ...</i>
		APPROVED: <i>[Signature]</i> 4/4/90

**BARFIELD INC
FOR REFERENCE ONLY**

- - - - - ENGINEERING SPECIFICATION - - - - -	
Title: Vertical Speed Indicator Ground Support Equipment	Barfield Instrument Corp. 4101 N.W. 29 Street Miami, FL. 33142
DRAWING NO: 23-337-A0025	Page 2 of 4

1. Purpose: To specify performance requirements for pressure actuated vertical speed indicators for use in B.I.C. manufactured ground support test equipment.

2. Scope: This engineering specification covers four (4) basic types of direct indicating instruments as follows:
 - Type I - Range 0-2000 feet per minute climb and descent.
 - Type II - Range 0-3000 feet per minute climb and descent.
 - Type III - Range 0-4000 feet per minute climb and descent.
 - Type IV - Range 0-6000 feet per minute climb and descent.

3. Identification: All units regardless of origin of manufacture are to be identified by B.I.C. assigned part numbers as follows:
 - Type I - to be identified as part number 337-00001.
 - Type II - to be identified as part number 337-00002.
 - Type III - to be identified as part number 337-00003.
 - Type IV - to be identified as part number 337-00004.

4. Test Conditions: Unless otherwise specified, all tests shall be made with the instrument mounted in the horizontal (Face UP) position.

5. Performance Requirements: All units are required to meet the following performance requirements before installation in any ground support test equipment.
 - 5.1 Zero Setting Range: The range of movement of the pointer by means of the zero adjustment shall not be less than 400 feet per minute for the "UP" and "DOWN" position.

 - 5.2 Scale Error: When subjected to the rates of changes of pressure indicated in Table 1 for the altitude intervals shown, the errors shall not exceed the tolerances specified.

 - 5.3 Lag: The natural lag of the instrument when timed between the following points shall be between 3 and 15 seconds.
 - Type I and II - 1800 - 200 feet per minute.
 - Type III and IV - 2000 - 200 feet per minute.

- - - - - ENGINEERING SPECIFICATION - - - - -	
Title: Vertical Speed Indicator Ground Support Equipment	Barfield Instrument Corp. 4101 N.W. 29 Street Miami, FL. 33142
DRAWING NO: 23-337-A0025	Page 3 of 4

5.4 Friction:

A test shall be performed to ascertain friction. In the time intervals at which the lag time is measured, the pointer shall move smoothly towards zero (while no vibration is applied) and shall return to zero within 300 feet of the initial reading.

5.5 Leak:

With a suction of 15 inches of mercury applied to the static pressure connection, the leakage shall not cause more than 0.05 inches of mercury pressure drop during a 1 minute period. With a pressure of 10 inches of mercury applied to the static connection, the leakage shall not cause more than 0.05 inches of mercury pressure drop during a 1 minute period.

5.6 Position Error:

With atmospheric pressure applied to the instrument, the difference between pointer indication when the instrument is in horizontal (Face UP) operating position and when it is in any other position shall not exceed 50 feet per minute.

7. Qualification Tests:

All instruments shall comply with the requirements of this section.

7.1 Vibration:

The instrument shall be subjected to vibration during testing. While the instrument is being vibrated, the drift of the pointer shall not exceed 50 feet per minute and it shall not oscillate more than 50 feet per minute.

- - - - - ENGINEERING SPECIFICATION - - - - -	
Title: Vertical Speed Indicator Ground Support Equipment	Barfield Instrument Corp. 4101 N.W. 29 Street Miami, FL. 33142
DRAWING NO: 23-337-A0025	Page 4 of 4

TABLE 1

SCALE ERROR TOLERANCE

TYPES I AND II

(Ranges: 0-2,000 and 0-3,000 Feet Per Minute)

Test Rate Ascent and Descent <u>Feet Per Minute</u>	Tolerance <u>Feet Per Minute</u>
500	35
1,000	75
1,500**	150
2,000	250
1,500**	200
2,000	250
1,500**	200
2,000	250

** Maximum test point for Type I.

SCALE ERROR TOLERANCE

TYPES III AND IV

(Ranges: 0-4,000 and 0-6,000 Feet Per Minute)

Test Rate Ascent and Descent <u>Feet Per Minute</u>	Tolerance <u>Feet Per Minute</u>
500	100
1,000	200
2,000	300
3,000**	300
4,000	400
5,000	500
2,000**	300
4,000	400
2,000**	300
4,000	400

** Maximum test point for Type III.

**BARFIELD INC
FOR REFERENCE ONLY**

THIS PAGE INTENTIONALLY LEFT BLANK