

AvionTEq

Test with full trust

www.avionteq.com



INSTRUCTION MANUAL

FOR

**8000
AC FUEL QUANTITY
TEST SET**

P/N 101-00540



**INSTRUCTION MANUAL
8000 Fuel Quantity Test Set**

**USERS ARE REQUESTED TO
NOTIFY THE MANUFACTURER OF
ANY DISCREPANCY, OMISSION OR
ERROR FOUND IN THIS MANUAL.
PLEASE SEND COMMENTS TO:**

**TECHNICAL CUSTOMER SUPPORT - GSTE
BARFIELD CORPORATION
P.O. BOX 025367
MIAMI, FL 33142
USA**

**TELEPHONE (305) 871-3900
(800) 321-1039**

FAX (305) 876-1680

EMAIL ADDRESS: Techsupport.GSTE@barfield.eads.net



INSTRUCTION MANUAL
8000 Fuel Quantity Test Set

ATTENTION

Although every effort has been made to provide the end user of this equipment with the most current and accurate information, it may be necessary to revise this manual in the future. Please be sure to complete and return a *Revision Request Form*.

Additionally, Barfield **MUST** have your name and address on file as a registered user of this equipment to ensure validation of the warranty. Please complete the **OWNER WARRANTY REGISTRATION** card promptly, and return it to:

Please submit questions or comments related to this manual in writing to:

Technical Customer Support - GSTE
Barfield
P.O. Box 025367
Miami, FL 33142
USA

Inquiries should include specific questions and always reference the publication title, number, chapter, page, figure, paragraph, and effective date.



INSTRUCTION MANUAL
8000 Fuel Quantity Test Set

REVISION RECORD

REV.	ECO #	REV. DATE	DESCRIPTION OF CHANGE
A	N/A	3/1/03	Initial Release. This manual replaces 57-101-00540.



INSTRUCTION MANUAL
8000 Fuel Quantity Test Set

LIST OF APPROVED REPAIR FACILITIES

The manufacturer of this equipment does not recommend the user to attempt any maintenance or repair. In case of malfunction, contact the manufacturer, to obtain the list of approved repair facilities worldwide, ensuring that this equipment will be serviced using proper procedures and certified instruments. A Return Maintenance Authorization (RMA) number will be assigned during this call, to keep track of the shipment and the service.

BARFIELD PRODUCT SUPPORT
DIVISION

Telephone (305) 894-5400
(800) 321-1039

Fax (305) 894-5401

Shipping Address:

Barfield, Inc.
4101 NW 29th Street
Miami, Florida 33142
USA

Mailing Address:

Barfield, Inc.
P.O. Box 025367
Miami, FL 33102-5367
USA



INSTRUCTION MANUAL
8000 Fuel Quantity Test Set

TABLE OF CONTENTS

- Title Page
- Attention Pages
- Revision Record Page
- List of Approved Repair Facilities
- Table of Contents
- List of Illustrations
- Introduction

GENERAL INFORMATION AND OPERATING INSTRUCTIONS	Chapter-Section
--	-----------------

Description	1-1
Characteristics, Specifications and Capabilities	1-2
Operation	1-3
Shipping	1-4
Storage	1-5



INSTRUCTION MANUAL
8000 AC Fuel Quantity Test Set

TABLE OF CONTENTS (CONTINUED)

CHAPTER 1

GENERAL INFORMATION AND OPERATING INSTRUCTIONS

	<u>PAGE</u>
INTRODUCTION	INTRO/ 1
1. PUBLICATION BREAKDOWN.....	1
2. IDENTIFICATION – MODIFICATION STATUS	1
3. RECERTIFICATION.....	2
SECTION 1. DESCRIPTION	1-1/ 1
1. PURPOSE	1
2. 8000 FRONT PANEL COMPONENTS	2
SECTION 2 CAPABILITIES AND SPECIFICATIONS	1-2/ 1
1. CAPABILITIES	1
2. SPECIFICATIONS	1
3. PHYSICAL DATA.....	2
SECTION 3. OPERATION	1-3 / 1
1. GENERAL INFORMATION	1
A. Methods of Calibration	1
(1) Method 1: Preferred Dry Tank.....	1
(2) Method 2: Alternate Wet Tank	1
2. PRELIMINARY	2
A. Battery Installation/Replacement	2
B. Battery Test Procedure	2
C. AC Power Supply Installation/Removal.....	2
3. PRECAUTIONS	2
4. SYSTEM INSULATION TEST	3
A. Aircraft Preparation	3
B. Test Set Configuration	4
C. Aircraft Connection	4
D. Insulation Test Procedure	5
5. INDIVIDUAL TANK UNIT INSULATION TEST	6
A. Test Set Configuration	6
B. Insulation Test Procedure	7



INSTRUCTION MANUAL
8000 AC Fuel Quantity Test Set

TABLE OF CONTENTS (CONTINUED)

	<u>PAGE</u>
SECTION 3. OPERATION	1-3 / 1
6. SYSTEM CAPACITANCE TEST	7
A. Test Set Configuration	7
B. Aircraft Connections	7
C. Capacitance Test Procedure	8
7. INDIVIDUAL TANK UNIT CAPACITANCE TEST	9
A. Bench Test Tank Units	9
B. Capacitance Test Procedure	10
8. AMPLIFIER TEST/CALIBRATION	11
A. Setting EMPTY Adjustment	12
B. Setting FULL Adjustment	13
9. SYSTEM CALIBRATION	13
A. Calibration Procedure Setup: Method 1	13
(1) Setting EMPTY Adjustment (Without Adapter Cable)	13
(2) Setting EMPTY Adjustment (With Adapter Cable)	14
B. Test Procedure (Method 1)	15
(1) Setting EMPTY Adjustment	15
(2) Setting FULL Adjustment	16
C. Calibration Procedure Setup: Method 2	16
(1) Setting EMPTY Adjustment (Without Adapter Cable)	16
(2) Setting EMPTY Adjustment (With Adapter Cable)	17
(3) Setting FULL Adjustment	17
SECTION 4. SHIPPING	1-5/ 1
1. RECEIVING	1
2. SHIPPING	1
SECTION 5. STORAGE	1-6/ 1
1. PROCEDURE	1



INSTRUCTION MANUAL
8000 AC Fuel Quantity Test Set

LIST OF FIGURES

SECTION	FIGURE	TITLE	PAGE
INTRO	1	Identification Label.....	1
INTRO	2	Owner Warranty Registration Card	2
INTRO	3	Limited Warranty Registration Card.....	2
1-1	4	8000 AC Fuel Quantity Test Set	1
1-1	5	8000 Front Panel	2
1-3	6	Insulation Test, Configuration #1	4
1-3	7	Insulation Test, Configuration #2	5
1-3	8	Insulation Test, Configuration #3	6
1-3	9	Insulation Test, Configuration #4	6
1-3	10	Capacitance Test, Configuration #1.....	8
1-3	11	Capacitance Test, Configuration #2.....	9
1-3	12	Capacitance Test, Configuration #3.....	10
1-3	13	Capacitance Simulation, Configuration #1	11
1-3	14	Capacitance Simulation, Configuration #2	11
1-3	15	Capacitance Simulation, Configuration #3	12
1-3	16	System Calibration (Method 1), Configuration #1.....	14
1-3	17	System Calibration (Method 1), Configuration #2.....	14
1-3	18	System Calibration (Method 1), Configuration #3.....	15



INSTRUCTION MANUAL
8000 AC Fuel Quantity Test Set

INTRODUCTION

1. PUBLICATION BREAKDOWN

This instruction manual establishes the standards of operation for the 8000 AC Fuel Quantity Test Set. This publication has been prepared using ATA Specification 101 as a guide.

Questions related to this manual should be submitted in writing to:

Barfield
P.O. Box 025367
Miami, FL 33102-5367
USA
Attn: Technical Customer Support - GSTE

Inquiries should be specific and refer to the publication title, number, chapter, page, figure, paragraph, and effective date.

Changes, when approved, will be published as revisions to the manual and distributed to all registered owners of this test set.

2. IDENTIFICATION - MODIFICATION STATUS

A. Identification label, similar to Figure 1 and located on the front bulkhead of the test set, provides the user with the following information:

Manufacturers' Name
Designation of Equipment
Equipment Part Number
Equipment Description

Equipment Modification
Equipment Options
Equipment Model Number
Equipment Serial Number

BARFIELD MIAMI, FL • ATLANTA, GA		P/N	
MOD	OPT	MADE IN THE USA	
A B C D E F	A B C D E F		
G H J K L M	G H J K L M		
M/N	S/N		

IDENTIFICATION LABEL
Figure 1



INSTRUCTION MANUAL
8000 AC Fuel Quantity Test Set

B. In addition to the identification label, there are three (3) other record forms packaged with the test set as follows:

- (1) The Owner's Warranty Registration card, (Figure 2), which is to be completed by the owner and returned to the Barfield within **ten (10) days** of purchase to insure automatic update of printed matter and validation of warranty.

OWNER WARRANTY REGISTRATION
RETURNING THIS CARD COMPLETED ENABLES US TO KEEP YOU
AUTOMATICALLY INFORMED OF TECHNICAL UPDATES and VALIDATES YOUR WARRANTY.

NAME _____ TITLE _____
DEPARTMENT _____
COMPANY _____
ADDRESS _____
CITY _____ STATE _____ ZIP _____
P/N _____ S/N _____ MODEL # _____
PURCHASED FROM _____ DATE _____
AIRLINE REPAIR STATION OEM
OTHER _____

INFORMATION GIVEN ON THIS BARFIELD, INC. WARRANTY CARD IS AND WILL REMAIN
STRICTLY CONFIDENTIAL AND WILL NOT BE SHARED. OW-28 REV / 04.00

OWNER WARRANTY REGISTRATION CARD
Figure 2

- (2) The Limited Warranty Statement Card, (Figure 3), which lists the manufacturer's obligation to the original purchaser.

LIMITED ONE YEAR WARRANTY

BARFIELD INSTRUMENT CORPORATION warrants to the original purchaser of this unit sold by us and/or our agent, and all the parts thereof, to be free from defects in material or workmanship under normal use and service within the specified ratings and operating conditions.

Its obligation under this warranty is hereby limited to the repair or replacement of this unit, or part thereof, which is returned to us within one year after date of invoice, suitably packaged in the original container or equivalent and which shall prove, after our examination, to be defective under terms of above paragraph.

No other warranty is expressed or implied. We are not liable for consequential damages.

Some states do not allow the exclusion or limitation of incidental or consequential damages so that the preceding limitations or exclusions may not apply to you. This warranty gives you specific legal rights and you may have other rights which vary from state to state.

This warranty does not include the cost of transportation charges to and from the factory.

The repair or replacement of this unit, or any part thereof, does not void or extend the original warranty.

BARFIELD INSTRUMENT CORPORATION reserves the right to discontinue this unit without notice, or to make modifications in design at any time, without incurring any obligation to make these modifications in units previously sold.

BARFIELD INSTRUMENT CORPORATION
4101 N.W. 29 Street
Miami, Florida 33142 U.S.A.

FORM 991-00001

LIMITED WARRANTY STATEMENT CARD
Figure 3

- (3) The Certificate of Calibration: Each new unit and re-certified unit is delivered with a Certificate of Calibration that shows the date of the last calibration and when the next calibration is due. It certifies the accuracy of the unit and lists the part number and serial number to which it applies.



INSTRUCTION MANUAL
8000 AC Fuel Quantity Test Set

3. RECERTIFICATION

The Test Set P/N 101-00540 has a one-year recertification requirement. The maintenance required by this unit must be performed by qualified technicians in a shop equipped with the necessary tooling and facilities.

SECTION 1: DESCRIPTION

1. PURPOSE

The Barfield 8000 Fuel Quantity Test Set (P/N 101-00540) is specifically designed to satisfy the need to service 3-wire guarded, capacitance-type Aircraft Fuel Quantity Systems. The Test Set is compact, lightweight and completely portable. It has a rugged, all metal, weatherproof carrying case with a removable cover for test and calibration of all major components and circuitry of the aircraft's Fuel Quantity System.

The standard lead package enclosed with the 8000 Test Set provides all accessories necessary (except for the adapter cables) to adapt the adapter cable, aircraft, or component to the Test Set. Please refer to the Barfield Ground Test Equipment catalog for further information.



8000 AC FUEL QUANTITY TEST SET
Figure 4

A. Adapter Cable

Each individual Aircraft Fuel Quantity System requires its own particular adapter cable(s) and specific instructions. Adapter cable configurations and interfaces vary widely to accommodate the variety of fuel systems. There is an extensive selection of adapter cables manufactured by Barfield Inc. to be used with the 8000 AC Fuel Quantity Test Set. Please contact the Barfield Ground Support Sales department or visit the Barfield website at <http://www.barfieldinc.com/ground.html> for further information.

INSTRUCTION MANUAL
8000 AC Fuel Quantity Test Set

B. Carrying Case

The carrying case is made of drawn aluminum for maximum strength. The lid is fitted with a bracket, which, when closed, contacts the ON/OFF switch in the ON position, and moves it to the OFF position.

2. 8000 FRONT PANEL COMPONENTS

Note: Refer to Figure 5 for item number identification.

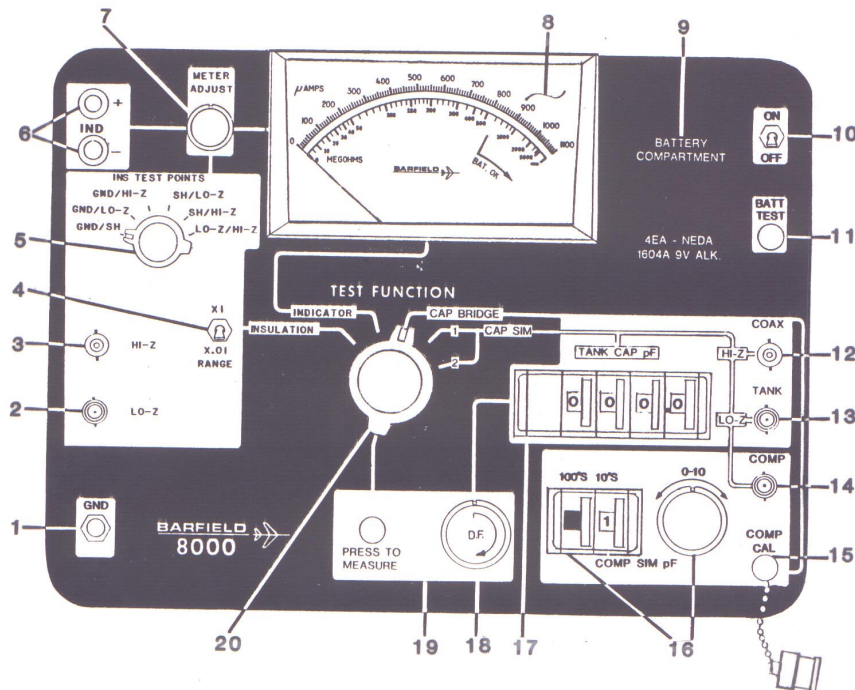

8000 FRONT PANEL COMPONENTS

Figure 5

- (1) The **GND** banana jack provides a connection to the Test Set's case ground.
- (2) The **LO-Z** is a polarized BNC receptacle for LO-Z insulation leakage tests.
- (3) The **HI-Z** is a BNC receptacle for HI-Z insulation leakage tests.
- (4) The **RANGE** select switch permits selection of x1 or x.01 MΩ for display during insulation tests.
- (5) The **INS TEST POINTS** selector switch permits selection of one of six (6) pairs of different test points for insulation leak tests.
- (6) The **IND ±** banana jacks provide indicator input connections for 0-1100 µA meter testing or substitution.
- (7) The **METER ADJUST** is a linear potentiometer that controls 0-1100 µA test current or adjusts the megaohmmeter for infinity (∞), full scale setting.
- (8) The **PANEL METER** is a DC taut-band micro ammeter. It provides the 0-1100 µA current scale, 0-5000 MΩ; 0-5000 MΩ scale and battery condition scale. Its circuitry components allow adjustments for all test functions from full scale to 1100 µA.



INSTRUCTION MANUAL
8000 AC Fuel Quantity Test Set

- (9) The **BATTERY COMPARTMENT** provides space for the batteries or the adapter for the auxiliary power supply.
- (10) The **ON/OFF switch** applies output power for all Test Set functions.
- (11) The **BATT TEST** pushbutton switch, when pressed, connects the meter as a full-scale 0-37.4 voltmeter across the battery supply. The **BAT. OK** radial line indicates 24.8 VDC. For the best calibration, there should be an indication of 880 μ A.
- (12) The **CAPACITANCE HI-Z COAX BNC** receptacle connects the HI-Z to the capacitance bridge and tank simulators.
- (13) The **CAPACITANCE LO-Z TANK**, a polarized BNC receptacle, connects the LO-Z to the capacitance bridge and tank simulators.
- (14) The **CAPACITANCE LO-Z COMP**, a polarized BNC receptacle, connects the LO-Z to the compensator simulator.
- (15) The **COMP CAL** pushbutton switch, when pressed, connects the compensator simulator to the capacitance bridge. (Shorting cap with chain is attached.)
- (16) The **COMP SIM pF** is a 100's-10's thumbwheel assembly and a 0-10 pF variable capacitor for setting compensator capacitance between HI-Z COAX and LO-Z COMP.
- (17) The **TANK CAP pF** thumbwheel assembly permits selection of capacitance value to be simulated between HI-Z COAX and LO-Z TANK connectors or bridge value.
- (18) The **D.F.** control is a variable capacitor for Dissipation Factor adjustment.
- (19) The **PRESS TO MEASURE** pushbutton switch, when pressed, activates the bridge VCC supply and switches the bridge for external use.
- (20) The **TEST FUNCTION** select switch permits selection of one of the five (5) test functions. When the Test Set is placed in the CAP SIM 1 or CAP SIM 2 function, the meter may be substituted for a DC meter-type fuel quantity indicator.



INSTRUCTION MANUAL
8000 AC Fuel Quantity Test Set

SECTION 2: CAPABILITIES AND SPECIFICATIONS

1. CAPABILITIES

When the 8000 Fuel Quantity T/S is connected through the appropriate adapter cables, the following functions may be performed:

- Measure capacitance of individual or interconnected tank units or units simulators
- Measure insulation resistance of wiring, tank units, or other discrete test points.
- Test the performance of indicators, signal conditioners, or bridge amplifiers.
- Simulate capacitance representative of empty or full tank units or systems, or the added capacitance effect of fuel between empty and full.
- Substitute the Test Set's meter for DC-type meter-movement type gauge, and provides adjustable metered current to test the gauges.
- Bench check system components.

2. SPECIFICATIONS

INSULATION

Range:	0 to Infinity (∞) in two scales: 5 to 5000 M Ω 50 k Ω to 50 M Ω
Accuracy:	$\pm 5\%$ of reading nominal, but not in excess of $\pm 2\%$ of scale length all through range
Applied Voltage:	10 VDC nominal
Current	50 nA maximum

INDICATOR

Range:	0-1100 μ A in 10 μ A increments
Accuracy:	$\pm 1\%$ of full scale

CAPACITANCE BRIDGE

Range:	0 to 999.9 pF in 0.1 pF increments
Accuracy:	\pm (0.1% of reading + 0.1 pF)
Signal:	400 Hz at 5.7 V RMS nominal



INSTRUCTION MANUAL
8000 AC Fuel Quantity Test Set

2. SPECIFICATIONS (continued)

CAPACITANCE SIMULATORS

Tank Range:	0 to 999.9 pF in 0.1 pF increments
Accuracy:	Same as Capacitance Bridge
COMP Range:	10-400 pF continuously adjustable
Accuracy:	Set with Capacitance Bridge
Maximum Input	75 V RMS, 220 V peak to peak (above 3 kHz, Tank Simulator limit decreases proportionately to 10 V RMS at 25 kHz)

INPUT POWER

Batteries	Four (4) Each, 9V Batteries
External Power	115V or 230V 50-400 Hz (A 115 V or 230 V may be substituted for the battery pack.)

3. PHYSICAL DATA

	In.	cm.
Height	5.3	13.5
Width	12.2	31.0
Depth	10.4	26.4
Length	12.3	31.0
	lbs.	kg
Weight	7.0	3.2



INSTRUCTION MANUAL
8000 AC Fuel Quantity Test Set

SECTION 3: OPERATION

1. GENERAL INFORMATION

Fuel Quantity Indicating Systems provide the aircraft crew with an accurate display of the remaining fuel. The quantity of fuel displays on the fuel quantity indicator(s) in the flight compartment.

The Fuel Quantity Indicating System includes the amplifier or signal conditioners (also known as the *amplifiers*) and the probe(s)/transmitter(s) that are installed in each tank (also known as the *Tank Unit*). A Tank Unit is a capacitor. It consists of two (2) conductive tubes separated by an air gap, or a combination of air and fuel. The Unit is connected to terminals that are, in turn, connected to the amplifier. This unit measures the fuel mass or weight. The volume or weight is determined by the dielectric constant of the insulating air or fuel, or air/fuel mixture in the tank; then, fed to other units for refinement or amplification before being displayed on the indicator.

Note: For more complete and detailed information on specific Fuel Quantity Systems, refer to the appropriate Aircraft/System Maintenance Manuals.

A. Methods of Calibration

There are two (2) methods of Fuel Quantity System calibration:

- Method 1: Dry Tank (PREFERRED)
- Method 2: Wet Tank (ALTERNATE)

(1) Method 1 (Preferred)

The Dry Tank method of calibration is done without fuel in the tank(s) and with the Tank Unit(s) dry. A capacitance value is substituted for an equivalent amount of fuel (full) in the tanks. The indicator is then adjusted to display this full level of fuel. (This method is more accurate since the indicator's zero (0) indication is set to the actual empty tank value thus ensuring the integrity of the system's empty level.)

(2) Method 2 (Alternate)

The Wet Tank method of calibration is done with fuel in the tanks. The Tank Unit is "electrically" removed from the Fuel Quantity Indicating System. Simulated values for both EMPTY and FULL adjustments are made to the indicator. The actual empty setting is questionable. Accuracy is sacrificed by using simulated values.

However, if correct, current dry tank capacitance values are available for the aircraft by serial number, these values should be used for the indicator EMPTY adjustment. The user may then add the ADD FOR FULL value to the current dry tank value to get the FULL adjustment value. (Refer to the Aircraft Maintenance manual.)



INSTRUCTION MANUAL 8000 AC Fuel Quantity Test Set

Note: Method 2 should be used **only** as a TEMPORARY measure. Method 1 should then be done at a more suitable time.

2. PRELIMINARY

The user should be familiar with the 8000 Fuel Quantity Test Set and its accessory lead package. The tests and procedures performed are dictated by requirements of the particular fuel quantity system. System components should be tested and their reliability verified before attempting calibration. *Refer to the aircraft and/or system manufacturer's maintenance manual for specific procedures and calibration values.*

A. Battery Installation/Replacement

Before battery installation, test each battery individually to ensure each battery is at peak load power.

- (1) Remove the two (2) screws from the battery holder assembly.
- (2) Lift, disconnect, and remove the battery holder assembly. (This aids installation.)
- (3) Observe polarity. Install the batteries and ensure the contacts mate.
- (4) Reconnect the battery plug.
- (5) Replace the battery holder assembly. Secure with the two (2) screws.

B. Battery Test Procedure

- (1) Set the Test Set's ON/OFF switch to ON.
- (2) Rotate the Test Set's TEST FUNCTION selector switch to CAP BRIDGE.
- (3) Press the BATT TEST pushbutton. Ensure the meter pointer deflection is beyond the BAT. OK radial line.

Note: Fresh batteries cause an 1100 measurement on the microamps scale. A reading of 880 μ A or greater ensures the best calibration. If the reading is not acceptable, replace with fresh batteries that test at peak load power.

- (4) Release the BATT TEST pushbutton.

C. AC Power Supply Installation/Removal (If applicable)

CAUTION: The 115 VAC 50-400 Hz or 230 VAC 50-400 Hz power supplies are meant for extended use at bench level maintenance. Operation onboard the aircraft may introduce unintended ground loops that could invalidate the test results. For this reason and because the power supplies **CANNOT** be used in the SIMULATION portion of the procedures due to grounding requirements, the manufacturer **DOES NOT** recommend these power supplies be used onboard the aircraft.

- (1) Remove the two (2) screws from the Battery Holder Assembly.
- (2) Lift, disconnect, and remove the Battery Holder Assembly.



INSTRUCTION MANUAL
8000 AC Fuel Quantity Test Set

- (3) Connect the connector from the power supply adapter (furnished with the power supply) to the Test Set connector removed from the Battery Holder connector.
- (4) Secure the adapter with the two (2) screws.
- (5) Using the Power Supply:
 - (a) Connect the power supply's input to a properly rated source.
 - (b) Connect the power supply's output to the AUX POWER receptacle in the power supply's adapter.
 - (c) Set the Test Set's ON/OFF switch to ON.
 - (d) Rotate the Test Set's TEST FUNCTION selector switch to CAP BRIDGE.
 - (e) Press the BATT TEST pushbutton and insure meter pointer deflection is beyond the BAT. OK radial line.
 - (f) Release the BATT TEST pushbutton.

3. PRECAUTIONS

- D. Refer to the appropriate maintenance or systems manual for operating instructions on specific aircraft systems and components and for proper defueling and fueling procedures.
- E. Observe all cautions and warnings.
- F. For all insulation and capacitance measurements, connect the ground clip lead between the T/S ground jack and airframe ground. Do not connect ground lead for capacitance simulation or system calibration.
- G. Turn off fuel quantity/refuel/defuel power while accessing or before a harness/cable or connector is removed.

4. SYSTEM INSULATION TEST

Note: If the system insulation test does not produce the required results, perform steps listed in section 5. INDIVIDUAL TANK UNIT INSULATION TEST.

A. Aircraft Preparation

- (1) Defuel the aircraft.
- (2) Open the appropriate circuit breakers.
- (3) Access the appropriate amplifier.
- (4) Disconnect and, if necessary, remove the amplifier.
- (5) Ensure that the T/S power switch is set to OFF and the aircraft power to the fuel quantity system is disconnected.
- (6) Turn aircraft power off when adapter harnesses are inserted or removed.

INSTRUCTION MANUAL
8000 AC Fuel Quantity Test Set

Caution: Connect the ground clip lead between T/S ground jack and airframe ground for all insulation and capacitance measurements. Do not connect ground lead for capacitance simulation or system calibration.

- (7) Remove all aircraft signal sources to the tanks.

B. Test Set Configuration

- (1) Verify that the Test Set battery is in working condition. (Refer to Battery Test Procedure, section 3, paragraph 2B.)
- (2) Set the TEST FUNCTION switch to INSULATION. Set the battery switch to ON.
- (3) Turn the Test Set's METER ADJUST to set the meter pointer to full-scale (∞).
- (4) For insulation readings below 20 M Ω , set the RANGE switch to x.01.
- (5) For insulation reading above 20 M Ω , set the RANGE switch to x1.
- (6) Connect the ground lead from the T/S's GND receptacle to a good airframe ground.
- (7) Rotate the Test Set's INS TEST POINTS selector switch to GND/SH.

Note: Some installations do not require this step. It may be omitted when not specified.

C. Aircraft Connection

- (1) Connect the appropriate adapter cable connector(s) to the aircraft connector(s). (Refer to Figure 6 or Figure 7.)
- (2) From the aircraft end of the adapter cable, connect: the HI-Z connector to the Test Set's HI-Z INSULATION receptacle and the LO-Z TANK connector to the Test Set's LO-Z INSULATION receptacle.

Note: Do not connect the connector(s) on the other end of the adapter cables.

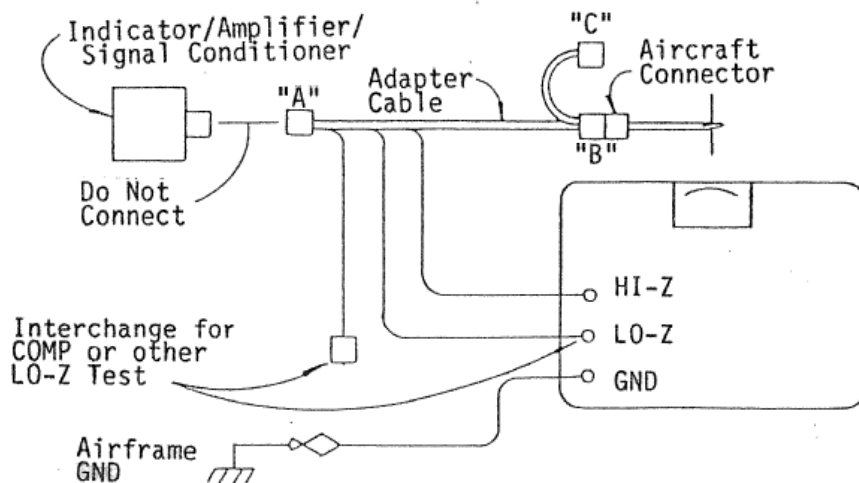

INSULATION TEST, CONFIGURATION #1
Figure 6

INSTRUCTION MANUAL
8000 AC Fuel Quantity Test Set

NOTE: Ensure that adapter cable connectors are not exposed to the airframe ground. It may be necessary to set an aircraft tank selector switch to the appropriate position to do the required test. Refer to the specific maintenance procedure or manual.

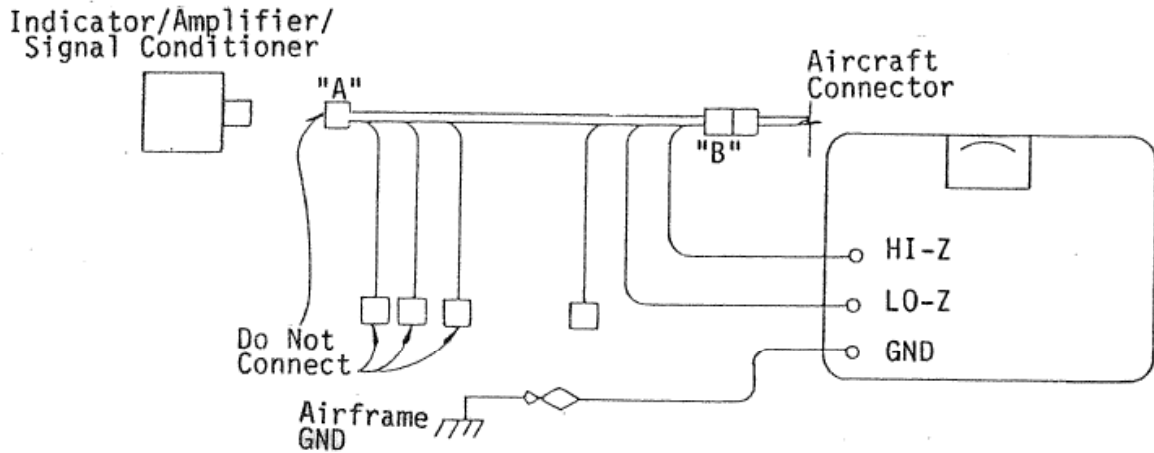

INSULATION TEST, CONFIGURATION #2
Figure 7

D. Insulation Test Procedure

Note: When using the manufacturer's adapter cables, ensure that the adapter's connectors and box are not exposed to the airframe ground. (The connectors, box and shielding "float" from ground for tests. Touching or grounding could cause incorrect readings.) *Do not touch the connectors or box while performing the test.*

Note: In order to do the desired test, it may be necessary to set an aircraft tank selector switch to a required position. Refer to the appropriate Maintenance Manual for the proper procedure.

- (1) Set the Test Set's ON/OFF switch to ON.
- (2) Read the resistance on the MEGOHMS scale and verify it is no less than the resistance listed for a shield to ground for the applicable aircraft.

Note: The meter pointer may drift slowly after initial movement due to capacitance charging time or presence of moisture. Allow pointer to stabilize or reach minimum acceptable scale value.

- (3) Rotate the INS TEST POINTS selector switch to each of the remaining positions.
- (4) If there are other HI-Z or LO-Z leads in the system, connect the panel receptacle to the corresponding pair and repeat test.

Note: References to compensator leads are to be considered LO-Z leads.

- (5) Reconfigure and repeat procedure for each corresponding pair.

INSTRUCTION MANUAL
8000 AC Fuel Quantity Test Set

- (6) Access the other amplifiers.
- (7) Reconfigure the Aircraft and the Test Set.
- (8) Repeat System Insulation Test for each tank system until all tanks are tested.
- (9) Place the Test Set's ON/OFF switch to OFF.
- (10) Disconnect all test equipment.
- (11) Continue to section 5, SYSTEM CAPACITANCE TEST. However, if the system insulation test does not produce the required results, perform steps listed 5. INDIVIDUAL TANK UNIT INSULATION TEST.

5. INDIVIDUAL TANK UNIT INSULATION TEST

Caution: Empty and purge fuel tanks before performing the Tank Unit Insulation test.

Note: It may be necessary to set an aircraft tank selector switch to perform the desired test. Refer to the appropriate Maintenance Manual for additional information.

A. Test Set Configuration

Configure the adapter cable and unit as shown in either Figure 8 or Figure 9.

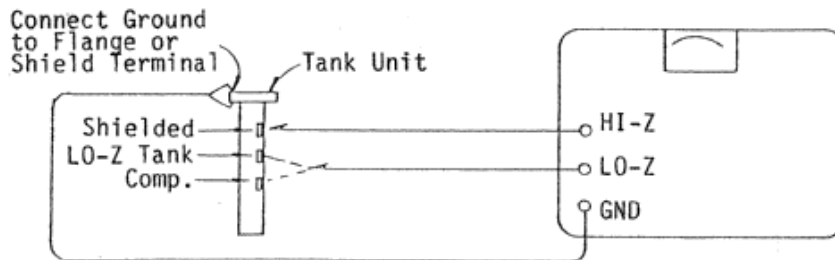

INSULATION TEST, CONFIGURATION #3

Figure 8

Note: Adapter harnesses are available from this manufacturer for connecting to certain aircraft equipped with probe system bulkhead connectors. The harness has a switch for selecting each of the individual probes for insulation and capacitance tests. It then connects directly to the test set receptacles for resistance or capacitance testing as shown in Figure 9.

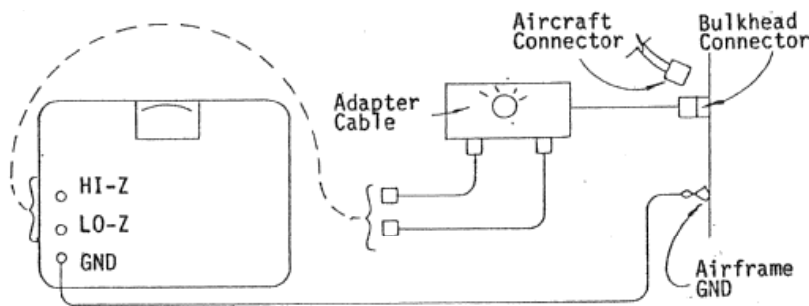

INSULATION TEST, CONFIGURATION #4

Figure 9



INSTRUCTION MANUAL
8000 AC Fuel Quantity Test Set

B. Insulation Test Procedure

- (1) Set the T/S TEST POINT switch to LO-Z/HI-Z.
- (2) Place the Test Set's ON/OFF switch to ON. (If configuration is Figure 9, also rotate the adapter's Probe Selector switch to one of its positions.)
- (3) Rotate the INS TEST POINTS selector switch to GND/SH.
- (4) Read the resistance on the MEGOHMS scale and verify that the resistance is not less than the resistance referenced for a shield to ground for the applicable aircraft.

NOTE The meter pointer may drift slowly after initial movement because of capacitance charging time or presence of moisture. Allow the pointer to stabilize or to reach minimum acceptable scale value.

- (5) Rotate the INS TEST POINTS selector switch to each of the remaining positions. Repeat step (4) for each switch position. (If configuration is Figure 9, access the other bulkhead connectors and repeat the procedure to read the resistance.)
- (6) Turn T/S set OFF.

Note: The **SYSTEM INSULATION TEST** (Section 3) should be performed after an individual insulation test and/or repair is done and *before* performing the **SYSTEM CAPACITANCE TEST** (Section 5) and/or system calibration.

6. **SYSTEM CAPACITANCE TEST**

Note: If the system capacitance does not produce the required results, perform the INDIVIDUAL TANK UNIT CAPACITANCE TEST (Section 7).

A. Test Set Configuration

- (1) Rotate the Test Set's TEST FUNCTION selector switch to CAP BRIDGE.
- (2) Rotate the D.F. control to the 12 o'clock position.

B. Aircraft Connections

Note: In order to do the desired test, it may be necessary to set an aircraft tank selector switch to a required position. Refer to the appropriate Maintenance Manual for the proper procedure.

- (1) Connect the adapter cable connector to the aircraft connector that has been removed from the amplifier. (Refer to Figure 10.)

INSTRUCTION MANUAL
8000 AC Fuel Quantity Test Set

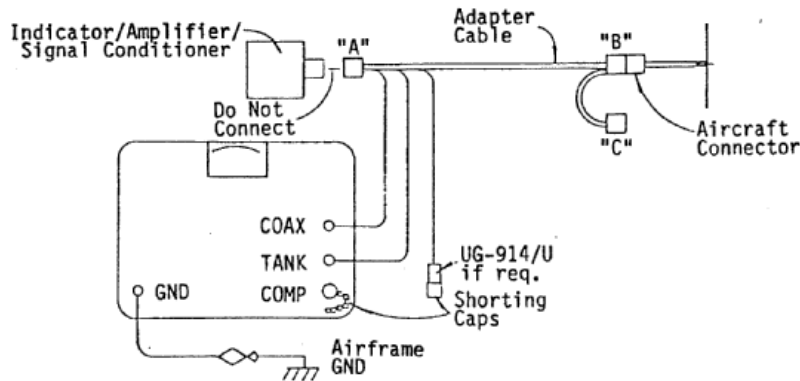

CAPACITANCE TEST, CONFIGURATION #1
Figure 10

Caution: Do not connect the connectors from the opposite end of the adapter cable.

- (2) Connect the HI-Z COAX lead to the Test Set's CAP BRIDGE HI-Z COAX receptacle and the LO-Z TANK lead to the Test Set's CAP BRIDGE LO-Z TANK receptacle from the adapter cable.

Caution: Short unshielded LO-Z leads and the Test Set's LO-Z COMP receptacle to ground with shorting caps or grounding lead connections.

Note: References to compensator leads mean LO-Z leads.

C. Capacitance Test Procedure

- (1) Set the Test Set's ON/OFF switch to ON.
- (2) Push and hold the PRESS TO MEASURE pushbutton while setting the TANK CAP pF thumbwheels for a meter null.

Note: If the nominal capacitance value is known, begin with the thumbwheels set to this value. If the nominal value is not known, set all thumbwheels to zero (0); then increase the left hand thumbwheel one digit at a time while the meter decreases. When the meter increases, reduce the setting by one digit. Repeat procedure for each thumbwheel, (moving to the right) until the best null is achieved. If the last or more digits indicate zero (0), reduce the previous digit by one (1) and search for a lower null.

- (3) Adjust the D.F. control for minimum null and verify a null of 100 μ A or less.

Note: Failure of the Tank unit to adjust to null may be due to poor HI-Z shielding in the aircraft. To troubleshoot, remove all 400 Hz power from the aircraft. If a high null continues, there may be high resistance connections, poor insulation, or a defective tank unit. *A failure to null means a short circuit. A very low capacitance reading at null means an open circuit.*

INSTRUCTION MANUAL
8000 AC Fuel Quantity Test Set

- (4) Release the PRESS TO MEASURE pushbutton.
- (5) If there are additional HI-Z and/or LO-Z leads in the system configuration, repeat the procedure for each corresponding pair.
- (6) Reconfigure the aircraft and the Test Set. Repeat the SYSTEM CAPACITANCE TEST for each tank system until all tanks are tested.
- (7) Set the Test Set's ON/OFF switch to OFF.
- (8) Disconnect all test equipment.
- (9) If necessary perform the INDIVIDUAL TANK UNIT CAPACITANCE TEST. If not, continue to 8. AMPLIFIER TEST/CALIBRATION.

7. INDIVIDUAL TANK UNIT CAPACITANCE TEST

Note: The SYSTEM CAPACITANCE TEST should be done after an individual capacitance test and/or repair but *before* doing the system calibration.

A. Bench Test Tank Units

Installed Tank Units may be measured through connections as shown in Figure 11, or may be measured through bulkhead connectors using an adapter cable as shown in Figure 12.

Note: The ground or shield connection of the Tank-Unit-Under-Test may be connected to the Test Set's GND receptacle. If the tank unit is a combination compensator and tank unit, the unshielded tank or compensator connection that is not used must also be connected to the Test Set's GND receptacle.

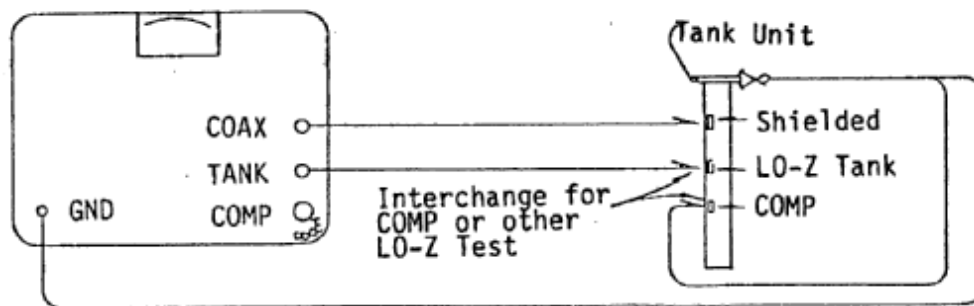

INDIVIDUAL TANK UNIT CAPACITANCE TEST, CONFIGURATION #1
Figure 11

INSTRUCTION MANUAL
8000 AC Fuel Quantity Test Set

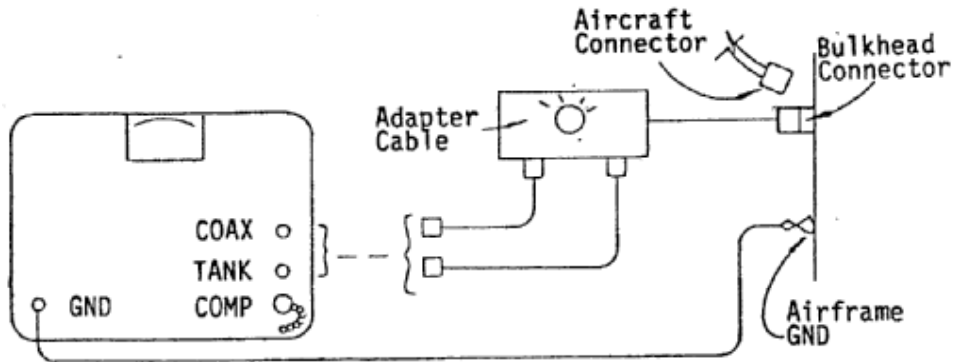

INDIVIDUAL TANK UNIT CAPACITANCE TEST, CONFIGURATION #2
Figure 12

B. Capacitance Test Procedure

Note: Refer to the appropriate maintenance manuals for individual tank unit locations and capacitance values by part numbers.

- (1) Set the TANK CAP pF thumbwheels to the value of the Tank-Unit-Under-Test. (If configuration is Figure 12, also rotate the adapter's PROBE SELECTOR switch to the position of the Tank-Unit-Under-Test.)
- (2) Press the PRESS TO MEASURE pushbutton.
- (3) Verify that the Test Set's meter pointer is null within tolerance of the Tank-Unit-Under-Test.
- (4) Release the PRESS TO MEASURE pushbutton.

Note: Failure to null within tolerance means there is a defective tank unit, bad connection or a poor pin contact. *Make the necessary repairs and repeat the test procedure.*

- (5) If there are additional HI-Z and/or LO-Z leads in the system configuration, repeat the procedure for each corresponding pair.
- (6) Reconfigure the aircraft and the Test Set. Repeat the SYSTEM CAPACITANCE TEST for each tank system until all tanks are tested.
- (7) Set the Test Set's ON/OFF switch to OFF.
- (8) Disconnect all test equipment.
- (9) If necessary, perform the INDIVIDUAL TANK UNIT CAPACITANCE TEST. Otherwise, continue to section 8. AMPLIFIER TEST/CALIBRATION.

INSTRUCTION MANUAL
8000 AC Fuel Quantity Test Set

8. AMPLIFIER TEST/CALIBRATION

The amplifier may be bench tested and calibrated with the appropriate independent cable, or with an adapter for the adapter cable used for aircraft test/calibration. The tank unit circuits are not used in the amplifier test and are “electrically” removed from the system.

Some adapter cables have leads that are wired through and are present at each end of the cable. (In those cases, the circuits must be disconnected elsewhere in the system.)

Other adapter cables with configuration connections are as follows:

- With multiple connectors at the aircraft end, one of which is wired without tank unit circuits to the amplifier as shown in Figure 13.

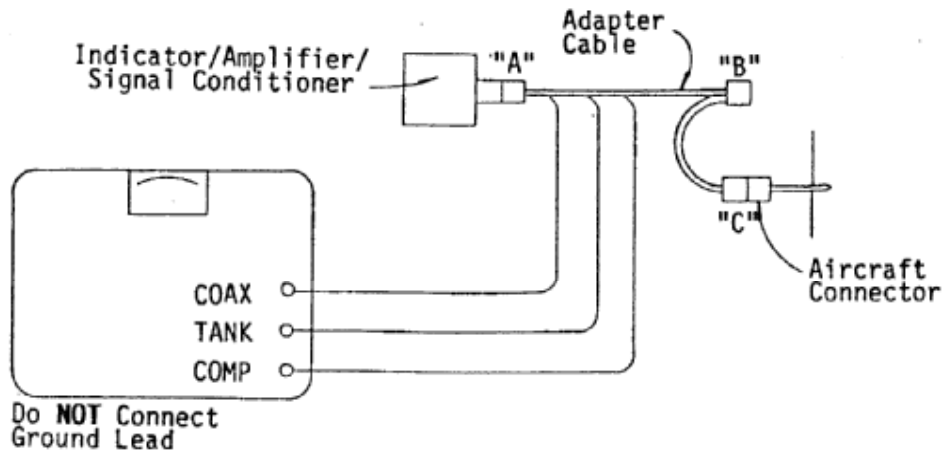

CAPACITANCE SIMULATION, CONFIGURATION #1

Figure 13

- With split leads from each end of the cable that is fitted with color-coded BNC connectors as shown in Figure 14. Connections are made with STRAIGHT or TEE BNC adapters as shown in the procedure.

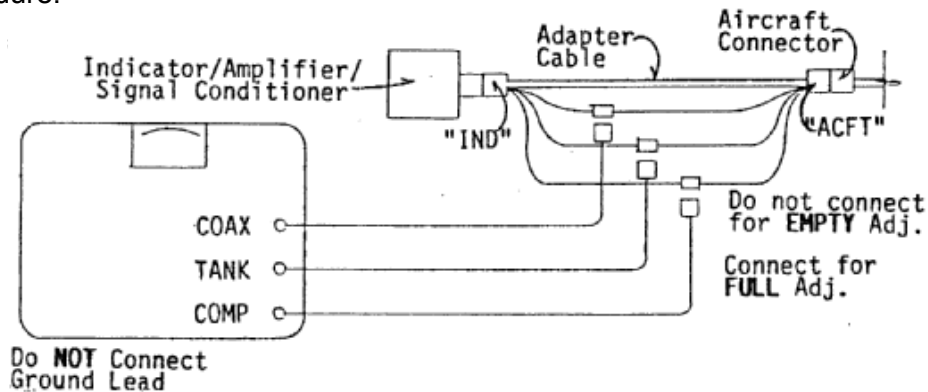

CAPACITANCE SIMULATION, CONFIGURATION #2

Figure 14

INSTRUCTION MANUAL
8000 AC Fuel Quantity Test Set

- With connectors for substituting the indicator as shown in Figure 15. The cable connections shown here are connected to the Test Set's IND ± jacks.

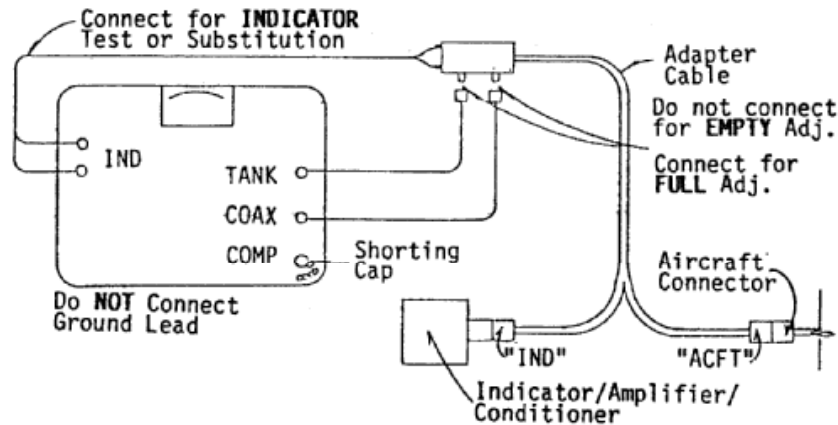

CAPACITANCE SIMULATION, CONFIGURATION #3
Figure 15

A. Setting "EMPTY" Adjustment

- (1) Identify the type of adapter cable to be used and connect the Test Set, adapter cable, amplifier and the aircraft wiring as shown in Figures 13, 14, or 15 accordingly.
- (2) Set the TEST FUNCTION switch to CAP BRIDGE.

Note: The Test Set's COMPENSATOR SIMULATOR (COMP SIM) is used to simulate a reference compensator capacitance. However, the COMP SIM can also be used to simulate a Tank Unit circuit. If the COMP SIM is not used, install the shorting cap on the Test Set's COMP RECEPTACLE.

- (3) Set TANK CAP pF by entering the EMPTY COMPENSATOR VALUE to be simulated on the thumbwheel assembly.
- (4) Set COMP SIM pF by entering the two left hand digits determined from step (3).
- (5) Set the Test Set's ON/OFF switch to ON.
- (6) Press and hold the COMP CAL pushbutton in. Alternate adjusting the COMP CAL 0-10 and D.F. controls for the lowest possible meter reading.
- (7) Rotate the TEST FUNCTION switch to CAP SIM 1.

Note: The CAP SIM 2 selection is used for certain "ratiometric" systems.

- (8) Connect the adapter cable's HI-Z COAX, LO-Z TANK and LO-Z COMP leads to the Test Set's corresponding receptacles as shown in Figures 13, 14, or 15.

Note: If there is no COMP connector, the LO-Z COMP may be used for a LO-Z TANK circuit.

- (9) Close the appropriate circuit breakers.
- (10) Turn aircraft power to the fuel system ON.
- (11) Adjust the amplifier E (EMPTY) adjustment to achieve a reading of ZERO or EMPTY.



INSTRUCTION MANUAL
8000 AC Fuel Quantity Test Set

B. Setting "FULL" Adjustment

- (1) Rotate the TEST FUNCTION switch to CAP BRIDGE.
- (2) Set the TANK CAP pF by entering the FULL COMPENSATOR VALUE to be simulated on the thumbwheel assembly.
- (3) Set COMP SIM pF by entering the two left hand digits, obtained from step (2), on the thumbwheel assembly.
- (4) Press and hold the COMP CAL pushbutton. Alternate adjusting the COMP CAL 0-10 and D.F. controls for the lowest possible reading.
- (5) Release the COMP CAL pushbutton.
- (6) Rotate the TEST FUNCTION selector to CAP SIM 1.
- (7) Adjust the amplifier F (FULL) adjustment to achieve an indicator reading of FULL or a "specified amount".

Note: Refer to the appropriate Maintenance Manual for capacitance values between EMPTY, ZERO and FULL or a "specified value" for the system-under-test to verify the indicator reading. Different TANK CAP pF values may be set to represent other levels of fuel.

- (8) Access the other fuel quantity amplifiers (if any) and repeat the adjustment procedure to all that apply.
- (9) Set the Test Set's ON/OFF switch to OFF.
- (10) Disconnect all test equipment.
- (11) Continue to section 9. SYSTEM CALIBRATION

9. SYSTEM CALIBRATION

Caution: Before doing a system calibration, test and validate insulation, capacitance and all other components of the system.

Note: Refer to the operating instructions in the appropriate Maintenance or Systems Manuals of specific aircraft/systems and/or components.

A. Calibration Procedure Setup: Method 1 –Dry Tank (Preferred)

Note: Some procedures specify empty adjustments be performed without adapter cables, or other test equipment connected to the system.

- (1) Setting "EMPTY" Adjustment - (*Without adapter cables*)
 - (a) Close the appropriate circuit breakers.
 - (b) If applicable to the system, select the appropriate tank.
 - (c) Set the EMPTY adjustments for the corresponding system.

INSTRUCTION MANUAL
8000 AC Fuel Quantity Test Set

(2) Setting EMPTY Adjustment - (*With adapter cables*)

- (a) Open appropriate circuit breakers.
- (b) Disconnect the amplifier and (if necessary) remove it.
- (c) Set up the test equipment.
- (d) Refer to Figures 16, 17 or 18 and configure the amplifier and the aircraft connector accordingly.
- (e) If appropriate to the system configuration, select the appropriate tank.

Note: *Do not connect the adapter cable to the test set at this time.*

1. Figure 16 shows an adapter cable with multiple connectors at the aircraft end. The Tank Unit circuits are wired in one branch to the connector attached to the amplifier.

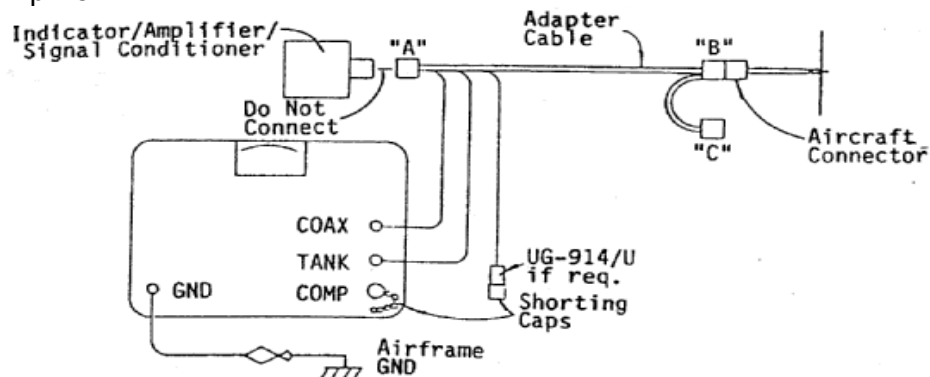

**SYSTEM CALIBRATION (METHOD 1), CONFIGURATION #1
MULTIPLE AIRCRAFT CONNECTORS**

Figure 16

2. **Figure 17** shows an adapter cable with split leads from each end of the cable fitted with color-coded BNC connectors. (In this case, connections are made with STRAIGHT or TEE BNC adapters.)

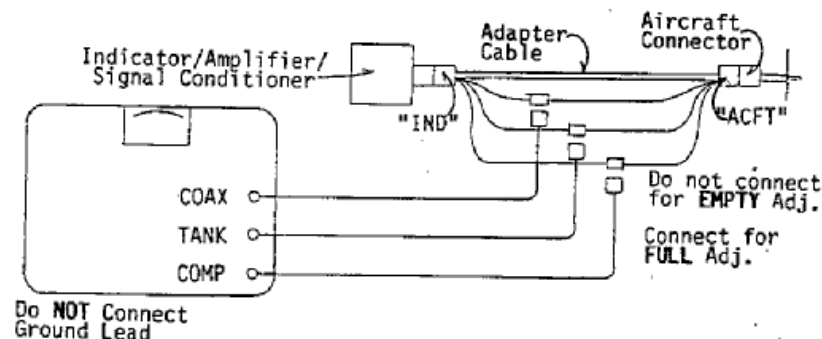

**SYSTEM CALIBRATION (METHOD 1), CONFIGURATION #2
SPLIT LEADS**

Figure 17

INSTRUCTION MANUAL
8000 AC Fuel Quantity Test Set

3. **Figure 18** shows an adapter cable with BNC connectors to substitute the amplifier. (The cable connections are made to the Test Set's IND \pm jacks.)

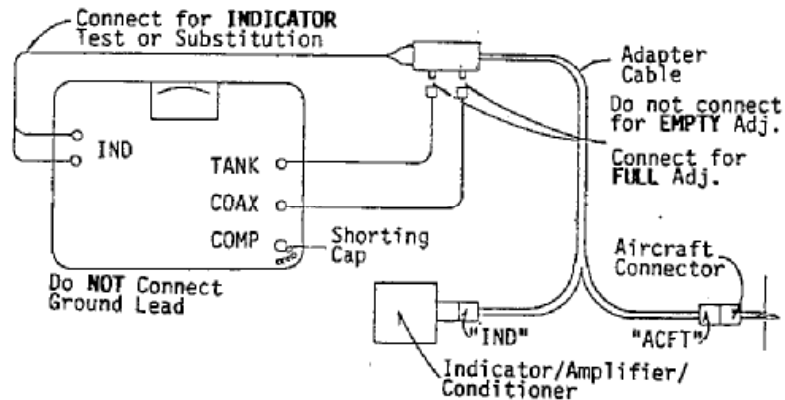

**SYSTEM CALIBRATION (METHOD 1), CONFIGURATION #3
BNC CONNECTORS
Figure 18**

Note: Some procedures require adding extra capacitance to represent a wetted compensator. Other procedures require that the sumps not be drained (leaving that amount of fuel to keep the compensator wet, i.e. unusable fuel).

Note: The Test Set's COMPENSATOR SIMULATOR (COMP SIM) is generally used to simulate a reference compensator capacitance. However, the COMP SIM can also be used to simulate a Tank Unit circuit. If the COMP SIM is not used, install the shorting cap on the Test Set's COMP RECEPTACLE.

B. Test Procedure (Method 1)

(1) Setting "EMPTY" Adjustment

- (a) Rotate the TEST FUNCTION selector to CAP BRIDGE.
- (b) Set the TANK CAP pF by entering the FULL COMPENSATOR VALUE to be simulated on the thumbwheel assembly.
- (c) Set the COMP SIM pF by entering the two left hand digits determined from step (b).
- (d) Close the appropriate circuit breakers.
- (e) Set the Test Set's ON/OFF switch to ON.
- (f) Press and hold the COMP CAL pushbutton while alternating adjusting the COMP CAL 0-10 and D. F. controls for the minimum reading.
- (g) Release the COMP CAL pushbutton.
- (h) Rotate the TEST FUNCTION selector to CAP SIM 1.

Note: The CAP SIM 2 selection is used with "ratiometric" systems.



INSTRUCTION MANUAL
8000 AC Fuel Quantity Test Set

- (i) Connect the adapter cable and the Test Set's COAX, TANK, and COMP receptacles as specified for the system-under-test.
- (j) Adjust the amplifier for E (EMPTY) adjustment to achieve a reading of EMPTY, ZERO (0).

(2) Setting "FULL" Adjustment

- (a) Rotate the TEST FUNCTION switch to CAP BRIDGE.
- (b) Set TANK CAP pF by entering the ADD COMPENSATOR VALUE to be simulated on the thumbwheel assembly.
- (c) Set COMP SIM pF by entering the two left hand digits determined from step (b).
- (d) Set the Test Set's ON/OFF switch to ON.
- (e) Press and hold the COMP CAL pushbutton while alternating adjusting the COMP CAL 0-10 and D.F. controls for the lowest possible reading.
- (f) Release the COMP CAL pushbutton.
- (g) Rotate the TEST FUNCTION switch to CAP SIM 1.

Note: The CAP SIM 2 selection is used with "ratiometric" systems.

- (h) Connect the adapter cable and the Test Set's COAX, TANK, and COMP receptacles as specified for the system-under-test.
- (i) Adjust the amplifier F (FULL) adjustment to achieve a reading of FULL.
- (j) Open the appropriate circuit breakers.
- (k) Set the Test Set's ON/OFF switch to OFF.
- (l) Disconnect the test equipment.
- (m) Return the aircraft to its original configuration.

C. Calibration Procedure: Method 2 – Wet Tank (Alternate)

Note: Method 2 should be used **only** as a TEMPORARY measure. Method 1 should then be done at first opportunity.

(1) Setting "EMPTY" Adjustment (Without adapter cable)

Note: Procedures often specify empty adjustments be done without adapter cable(s) or other test equipment connected to the system.

- (a) Close appropriate circuit breakers.
- (b) If applicable to the system, select the appropriate tank.
- (c) Set the EMPTY adjustments for the corresponding system.

(2) Setting "EMPTY" Adjustment (With adapter cable)

CAUTION Ensure Fuel Quantity/Refuel/Defuel power is off while accessing and before removing any harness, cable or connector. Maintain power off until while making connections.



INSTRUCTION MANUAL
8000 AC Fuel Quantity Test Set

- (a) Open the appropriate circuit breakers.
- (b) Access, and if necessary, remove the amplifier.

Caution Refer to the appropriate Maintenance manual for access procedures.
Observe all precautions.

- (c) Verify the Test Set's battery condition. (Refer to Battery Test Procedure, section 3, paragraph B.)
- (d) Place the test equipment in a convenient location and configure the amplifier, adapter cable and the aircraft wiring as shown in Figures 16, 17 or 18 according to the system configuration.
- (e) Rotate the TEST FUNCTION switch to CAP BRIDGE.
- (f) Set TANK CAP pF by entering the EMPTY COMPENSATOR VALUE to be simulated on the thumbwheel assembly.

Note: If the actual dry capacitance value for the particular aircraft serial number is known, substitute that value for EMPTY.

- (g) Set COMP SIM pF by entering the two left hand digits from step (f) on the thumbwheel assembly.
- (h) Close appropriate circuit breakers.
- (i) Set the Test Set's ON/OFF switch to ON.
- (j) Press and hold the COMP CAL pushbutton while alternating adjusting COMP CAL 0-10 and D.F. controls for the lowest possible reading.
- (k) Release the COMP CAL pushbutton.
- (l) Rotate the TEST FUNCTION selector to CAP SIM 1.

Note: The CAP SIM 2 setting is used with certain "ratiometric" systems.

- (m) Connect the adapter cable and the Test Set's COAX, TANK and COMP receptacles as specified for the system-under-test.
- (n) Adjust the amplifier E (EMPTY) adjustment to achieve a reading of EMPTY, ZERO (0).
- (o) Set the Test Set's ON/OFF switch to OFF.
- (p) If connected, disconnect the adapter cable and the Test Set's COAX, TANK, and COMP receptacles.

(3) Setting "FULL" Adjustment

- (a) Rotate the TEST FUNCTION selector to CAP BRIDGE.
- (b) Set TANK CAP pF by entering the sum of ADD COMPENSATOR VALUE and EMPTY VALUE on the thumbwheel assembly.
- (c) Set COMP SIM pF by entering the two left hand digits determined in step (b) on the thumbwheel assembly.
- (d) Place the Test Set's ON/OFF switch to ON.
- (e) Press and hold the COMP CAL pushbutton while alternating adjusting the COMP CAL 0-10 and D.F. controls for the lowest possible reading.



INSTRUCTION MANUAL
8000 AC Fuel Quantity Test Set

- (f) Release the COMP CAL pushbutton.
- (g) Rotate the TEST FUNCTION selector to CAP SIM 1.

Note: The CAP SIM 2 setting is used with certain “ratiometric” systems.

- (h) Connect the adapter cable and the Test Set’s CAPACITANCE COAX, TANK, and COMP receptacles as specified for the system-under-test.
- (i) Adjust the amplifier F (FULL) adjustment to achieve an indicated reading of FULL as specified.
- (j) Set the Test Set’s ON/OFF switch to OFF.
- (k) Disconnect all test equipment.
- (l) Return the aircraft to its original configuration.



INSTRUCTION MANUAL
8000 AC Fuel Quantity Test Set

SECTION 4: SHIPPING

1. RECEIVING

- A. No special unpacking procedures are necessary. It is recommended that the factory-shipping container and packing materials be kept should it become necessary to reship the Test Set.
- B. It is also recommended that the Test Set and its carrying case be carefully inspected for damage. If damaged, notify the carrier and the manufacturer immediately.

2. SHIPPING

- A. Use standard delicate electronic equipment packaging procedures when packing the adapter for reshipment.

CAUTION: Do not pack loose cables or other accessories inside the carrying case.

- B. All accessories should be stored/packaged in separate containers. Do not place in the carrying case.
- C. Remove the batteries.
- D. Insure all panel screws, panel components, and the cover is securely fastened.



INSTRUCTION MANUAL
8000 AC Fuel Quantity Test Set

SECTION 5: STORAGE

1. PROCEDURE

- A. For prolonged storage, remove the batteries.
- B. Place a four (4) ounce bag of desiccant inside the case.
- C. Close and latch the cover.
- D. Store in a cool, dry place.

Note: Should the Test Set become exposed to water or very high humidity, dry as soon as possible. Remove the Test Set from its case and temporarily store it in a dehumidified area.