

To buy, sell, rent or trade-in this product please click on the link below:
<https://www.avionteq.com/DeVORE-Aviation-FMG-4400D-Flash-Measuring-Gun>

AvionTEq
www.avionteq.com

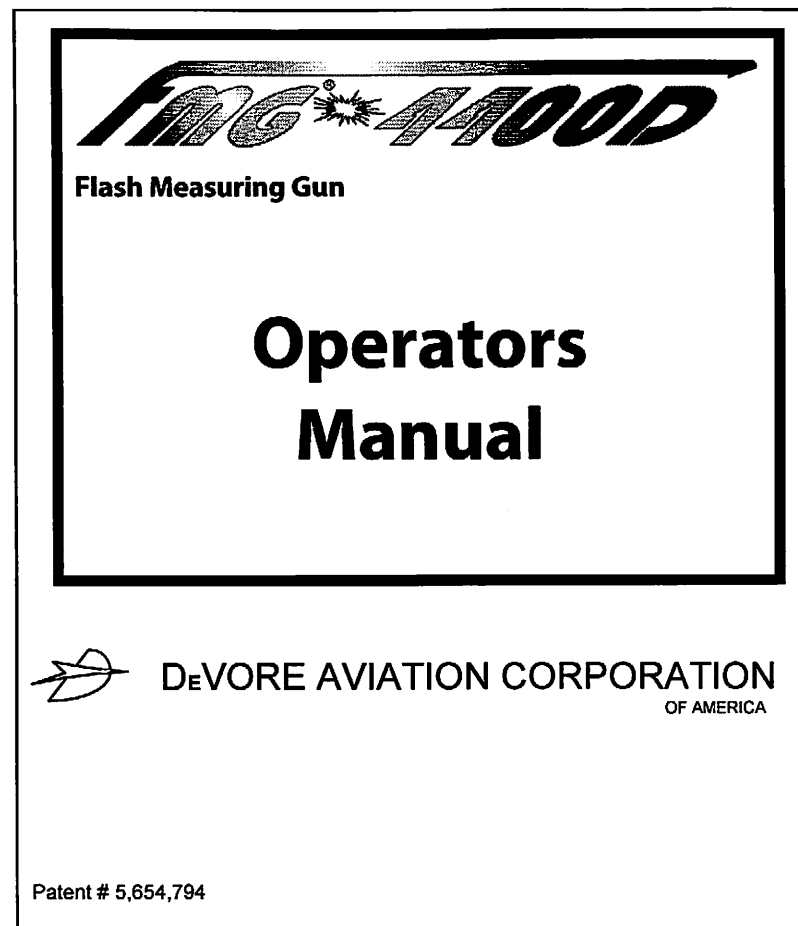

Manual No FGC00105

Table of Contents

FMG 4400D

- Introduction 2
 - The Flash Measuring Gun Described 2
 - Features 3
- Useful Information 4
 - Properties of Light 4
 - Strobe Measurement Basics 7
 - FAA Requirements for Aircraft Anti-collision Lights 7
- Operation 10
 - Using the Wand 10
 - Obtaining Consistent Readings 12
- Care and Maintenance 13
 - Recharging the Batteries 13
 - Cleaning the Sensor Lens 13
 - Yearly Calibration 14
 - Accessories 14
 - Opening the Housing 15
 - Mechanical Assembly 16
 - Mechanical Assembly (for serial numbers prior to:xxxxxxx) 17

WARRANTY

- Warranty 18

FMG 4400D

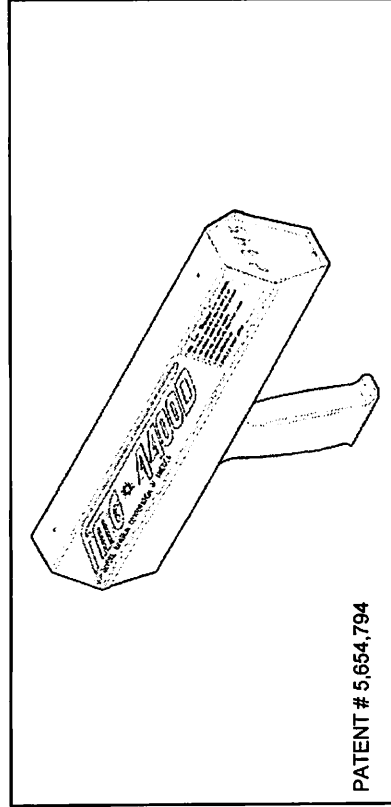

PATENT # 5,654,794

FMG4400D Digital Readout Strobe Intensity Measuring Instrument

INTRODUCTION

THE FLASH MEASURING GUN DESCRIBED

The FMG4400D is a hand held, digital flash intensity measuring instrument.

The FMG4400D has been accepted by the Federal Aviation Administration for use in determining the flash intensity of strobe type Anti-Collision Lights (ACL's) as part of a program of continued airworthiness and maintenance.

Warranty



Each new FMG4400D is warranted to be free of defects in material or workmanship under normal use, conditions, and service. Our obligation under this Warranty is limited to making good at our factory any part or parts thereof which shall, within three years after the purchase date, be returned to us with transportation charges prepaid, in the original case, and which upon our examination shall disclose to our satisfaction to have been thus defective. This Warranty being expressly in lieu of all other warranties, expressed or implied, and all other obligations or liabilities on our part. We neither assume nor authorize any other person to assume for us any other responsibility in connection with the sale of our products.

DeVore Aviation warrants the battery pack for a period of one year after the purchase date.

This Warranty will not apply to any FMG4400D which has been repaired or altered outside of our factory in any way, or which has been subject to misuse, neglect or accident.



The instrument uses a custom photo diode sensor furnished with laboratory grade optical filters that have been calibrated to match the human eye response to the visible spectrum. This allows the FMG4400D to accurately determine the intensity of both white and colored (generally red) strobes.

The FMG4400D displays the intensity of each strobe flash, as they occur, in equivalent candelas as defined by the Blondel Rey equation for computation of effective intensity.

FEATURES

- Hand held. Weighs less than 2 3/4 lbs.
- Four digit numerical readout.
- Instant display of the intensity of each strobe flash.
- Laboratory grade optics. Can measure both white and colored strobes.
- Electronics incorporate a RISC microprocessor operating at 8 MHz.
- Automatic compensation for ambient light conditions. The unit is usable day and night, outdoors and indoors.
- Battery operated using rechargeable NiCad batteries. The unit is supplied with a recharging transformer.
- Provides a unique method for establishing proper measurement distance.
 - A folding wand which slips into the front of the instrument and is used by placing the wand end at the center of the strobe flash tube.

USEFUL INFORMATION

PROPERTIES OF LIGHT

INTENSITY: The candela (cd) is the SI unit of luminous intensity. The luminous flux density received on a surface (illuminance) varies with the intensity of the source, and inversely as the square of the distance from the source to the surface. Illuminance is expressed in lumens per unit area or foot-candles.

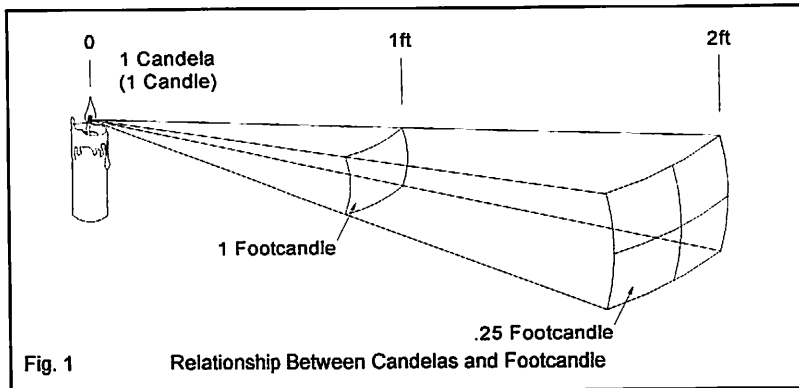
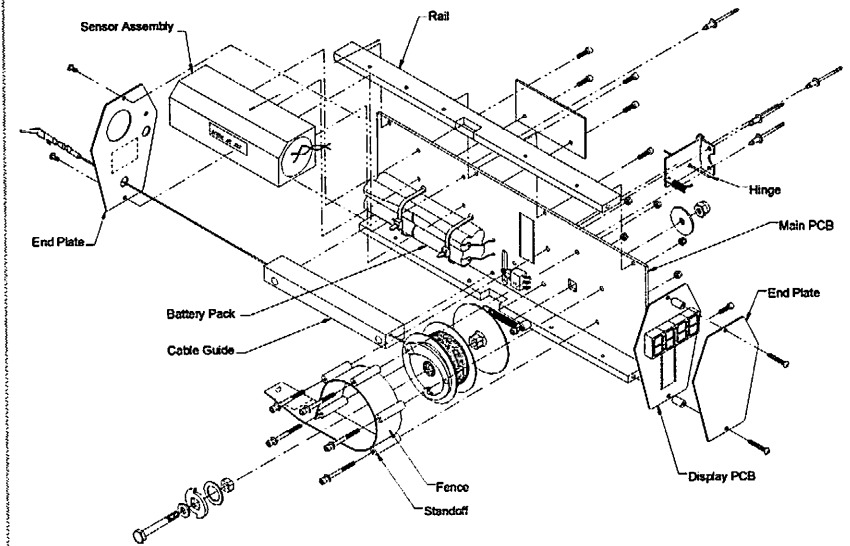

Figure 1 shows that as the distance from a source increases, light is spread over increasing areas, and the illuminance decreases. The relation of illuminance to distance from the source is referred to as the "inverse square law". The illuminance from a given source varies inversely as the square of the distance from that source. Doubling the distance causes the illuminance to decrease to one fourth.



Mechanical Assembly

Fig. 10

*For serial numbers prior to: 1604

3. **LOCATION OF WAND.** The tip of the wand should be located within ± 1.0 inch of the flash tube's vertical plane (Fig. 6). The wand should also be placed to the side to assure that the wand does not block light from reaching the sensor (Fig. 5). With the wand tip in place, apply appropriate directional pressure to the wand to align the instrument with the strobe light. Pull and hold the trigger to activate the instrument.

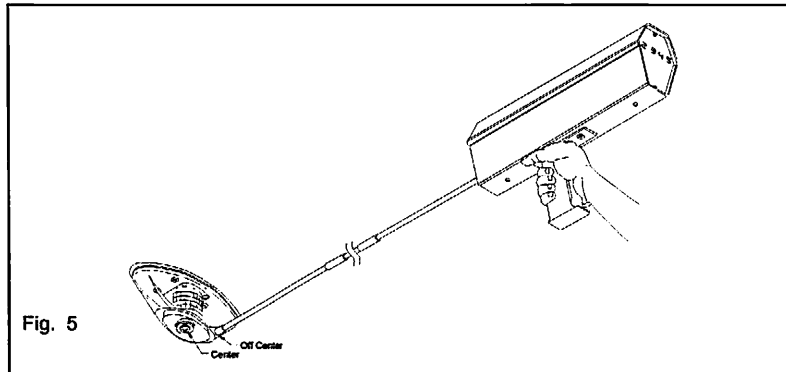

4. **BATTERY CHECK.** Upon pulling and holding the trigger, the instrument will display all four zeros for one second in order to perform a battery check. If battery power is sufficient, the third display will illuminate a single bar and the instrument is now ready to begin measurements.

If there is insufficient battery power, the display will flash "LO" then "BATE" continuously until the instrument is turned off. If "LOBATE" is displayed, the unit needs to be recharged. If immediate use is necessary, plug the recharging transformer into the unit and the instrument can be used after twenty minutes. A full charge takes 12 to 24 hours.

5. **ACQUIRING THE STROBE LIGHT.** Turn Strobe on. **DO NOT LOOK DIRECTLY AT THE STROBE.** In order to obtain the correct reading, the sensor must be aimed directly at the strobe within $\pm 5^\circ$ of the strobe's horizontal plane (Fig. 6). Once the instrument begins displaying readings, adjust the aim slightly until a maximum reading is obtained. **BE SURE THE WAND IS NOT OBSCURING THE LIGHT.**

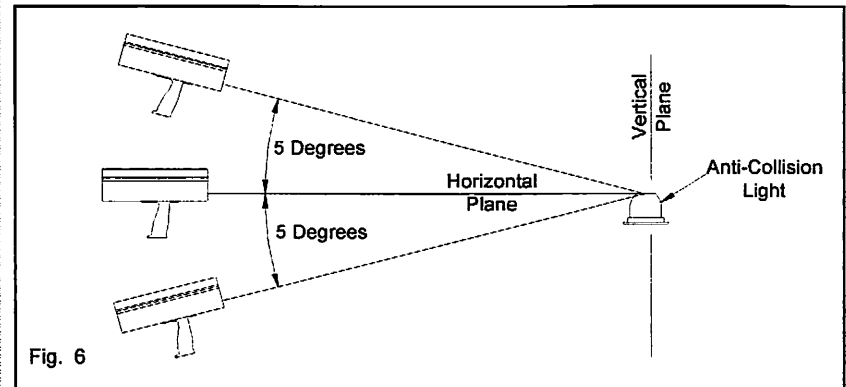

6. **LED DISPLAY.** Record the maximum readout in the appropriate records. The readout is in equivalent candelas.

7. **RE-FOLD THE WAND.** The wand re-folds by pulling apart each section and folding the rod. Store the rod behind the foam in the lid of the case.

OBTAINING CONSISTENT READINGS

The following are recommended procedures which, if adhered to, will assist the operator in obtaining consistent statistical data on strobe light intensities.

1. A clean lens makes a *big* difference! Clean both the inside and outside of the strobe cover lens. Replace if excessively blackened or damaged.
2. Due to the shape of strobe light cover lenses and the configuration of the strobe bulbs, readings will vary with the azimuth position about the strobe. In order to achieve consistent data, the instrument should acquire flashes from an identical location on each strobe light of the same design.
3. Always use the wand, which consistently fixes the instrument at the same distance from the strobe light.
4. The instrument should be held as close as possible to the horizontal plane of the strobe light.
5. A strobe light with a red glass lens should be turned on and then tested within the first few minutes. If the red glass lenses are allowed to warm up, the lens darkens and reduces light output. During normal operation the red glass lenses are cooled by air flow.
6. Once the instrument begins to display readings, adjust the aim slightly until a maximum reading is obtained.

OPERATION

OPERATION USING THE WAND

1. **UNFOLD WAND.** The shock cord running through the center of the graphite rods will automatically pull each wand section into the next as the wand unfolds, fully extending the wand. This can be done with one hand holding the wand by the end opposite the yellow tip. The wand is stored behind the foam in the lid of the case.
2. **INSERT WAND IN MOUNTING HOLE.** Slip the wand into the mounting hole (Fig. 4). Make sure that the wand is seated in the bottom of the hole as this will affect the distance of the instrument to the strobe light.

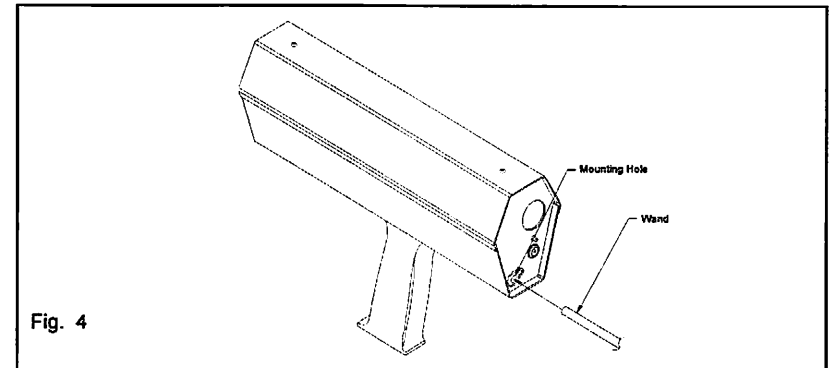

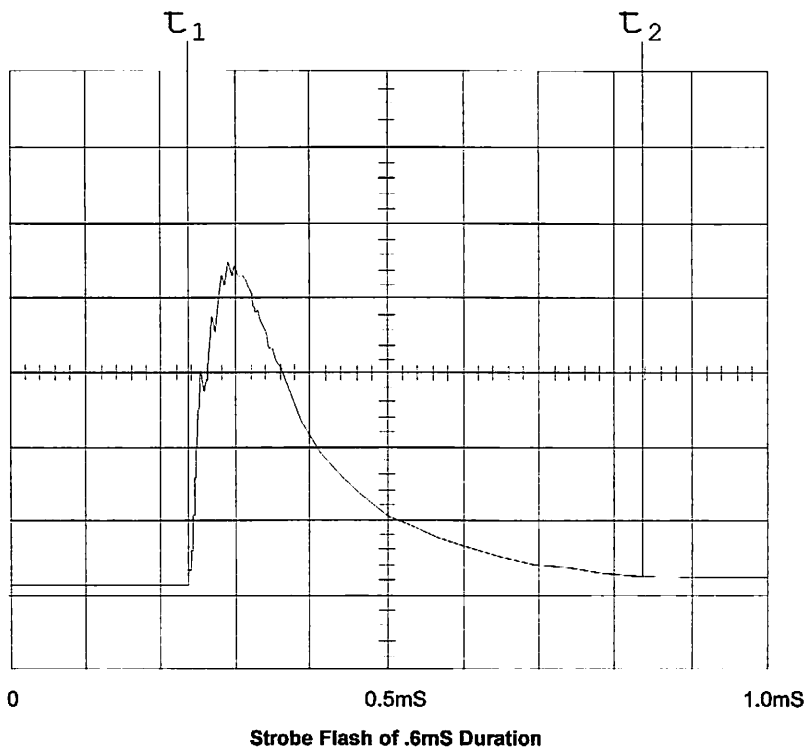
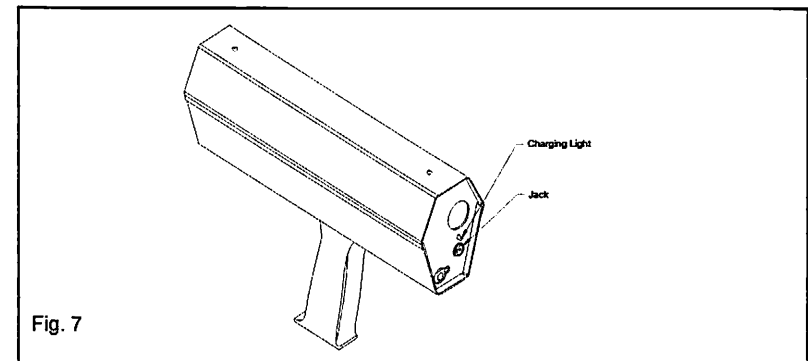

Fig. 3

CARE AND MAINTENANCE

RECHARGING THE BATTERIES

When the instrument indicates "LOBBE", the batteries need to be recharged. To recharge the batteries, simply plug the supplied transformer (12VDC output) into the jack located on the front panel (Fig. 10). A charging light (red LED) will illuminate indicating that the batteries are being recharged.



CLEANING THE SENSOR LENS

WARNING: USE CANNED AIR ONLY. The lens has a non-reflective coating which can be damaged if touched. Use of any solvent, water, rags or even air from an air compressor (it contains lubricating oil) can damage the coating on the sensor lens. Use only canned air to blow dust off the lens.

YEARLY CALIBRATION

The FMG4400D is a precision measurement instrument and must be calibrated yearly to maintain FAA acceptance of the instrument when used as part of an aircraft strobe anticollision light maintenance program. The instrument's calibration is traceable to NIST standard 37110S.

A calibration sticker is affixed to the front plate of the FMG4400D. This sticker indicates date of calibration and next required calibration.

When returning the instrument for calibration, it is important to ship the instrument in its original protective carrying case in a card board carton. This will ensure that the unit is not damaged in transit. Ship the unit to the following address:

DeVore Aviation Corporation of America
6104-B Jefferson, N.E.
Albuquerque, NM 87109-3410

Due to inherent cycle life of NiCad rechargeable batteries, it is recommended that the battery pack be replaced with a fresh battery pack at calibration time. This will ensure that the instrument is always ready for operation throughout the following year of service.

ACCESSORIES

The following accessories are available as spares and may be ordered from DeVore Aviation Corporation of America:

<u>Item</u>	<u>Part Number</u>
Transformer 115 VAC, 60 Hz	FMG41038-1
Transformer 230 VAC, 50 Hz	FMG41039-1
Wand	FMG41027-1
Anchor Pin	FMG41035-11
Battery Pack Kit	FMG41036-1

STROBE MEASUREMENT BASICS

When a light signal consists of separate flashes, the maximum intensity during the flash must be greater than the intensity of a steady light to have the same apparent intensity. It is convenient to evaluate flashing lights in terms of their Effective Intensity, I_e .

Current airworthiness requirements for aircraft anti-collision lights specify the following equation, known as the Blondel-Rey Equation, for the computation of effective intensity.

$$I_e = \frac{\int_{t_1}^{t_2} I(t) dt}{0.2 + (t_2 - t_1)}$$

where: I_e = effective intensity expressed in candelas

$I(t)$ = instantaneous intensity as a function of time

$(t_2 - t_1)$ = flash time interval in seconds (Fig 3)

FAA REQUIREMENTS FOR ANTI-COLLISION LIGHTS

Refer to the aircraft's certification requirements for anti-collision light intensity values.

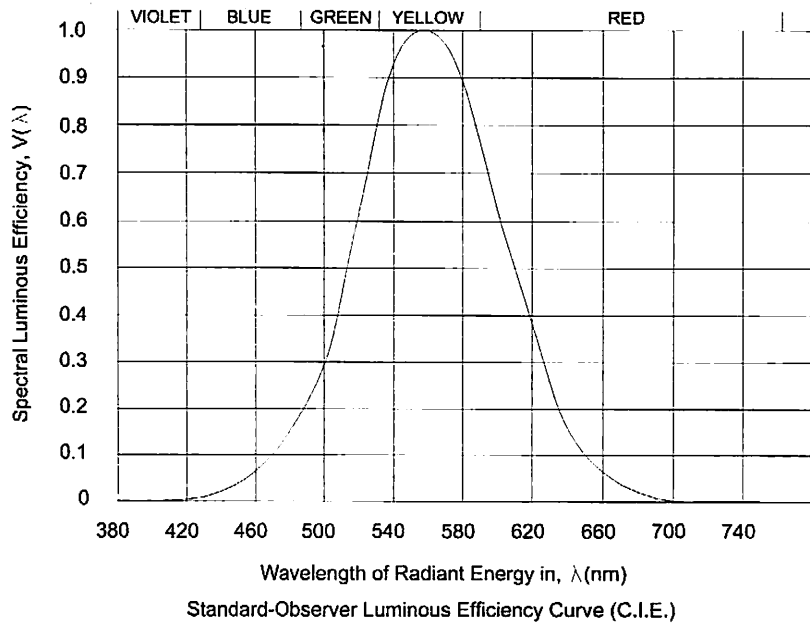

Fig. 2

OPENING THE HOUSING

There are no serviceable internal parts on this instrument. If it fails to operate for any reason, return the unit to DeVore Aviation Corporation of America. If you should find it necessary to open the unit first remove the two mounting screws on the top and the four screws along the bottom (Fig. 8). Then carefully slide the unit out of the housing. To reassemble, slide the unit into the housing and replace the screws.

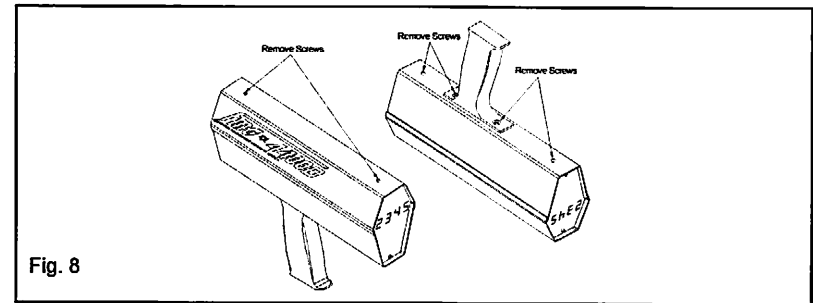
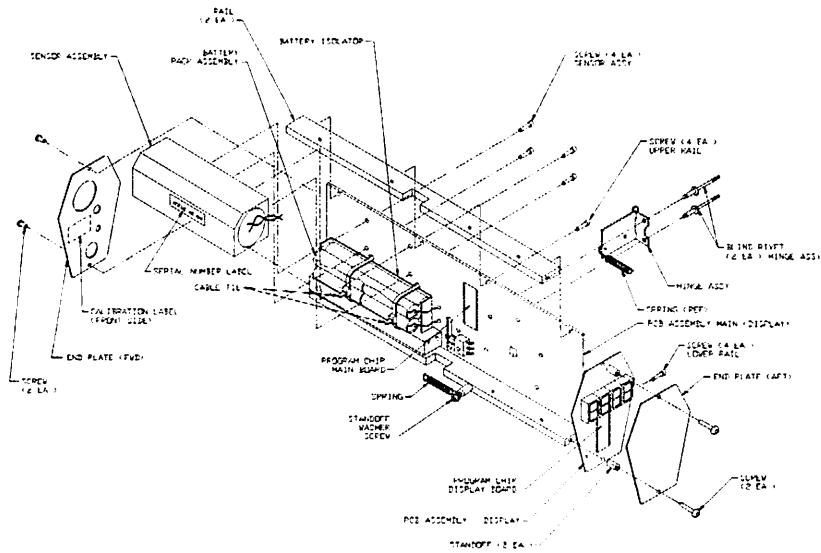

Fig. 8



Mechanical Assembly

Fig. 9

*For serial numbers after: 1604

As measurements of a light source are done with instruments which measure illuminance, the distance must be known before the intensity of the source can be determined. Foot-candle, the measured illuminance, times the distance squared gives candelas, the source luminous intensity.

COLOR: Light energy may be considered as having a sinusoidal wave form, stimulating vision only over a narrow band of wavelengths. Within this band, the longest waves produce a sensation of red, and the shortest a sensation of violet. By definition, white occurs when all visible wavelengths are combined in equal amounts.

The sensitivity of the eye varies within this visible spectrum. Radiant energy at different wavelengths produces varying sensations of brightness even though the amount of energy received is the same at each wavelength. Figure 2 shows the human eye response to constant radiant energy over the visible range. This curve is referred to as "spectral sensitivity of the human eye" or "luminous efficiency". Note, for example, that the eye is nearly three times as sensitive to yellow light at 560nm as it is to red light at 620nm.

When the intensity of colored lights is measured, this variable sensitivity of the eye must be taken into consideration. In other words, a red light must be much higher in power to appear equally as bright as a yellow light. The detecting device, therefore, must be corrected for the response of the standard observer if the reading is to indicate luminous (visual) output.